



Quantum Entanglement
& Macroscopic **Quantum** superpositions

Dirk Bouwmeester

University of California, Santa Barbara, US
&
University of Leiden, the Netherlands

Vancouver, November 16, 2011

13.700.000.000 years

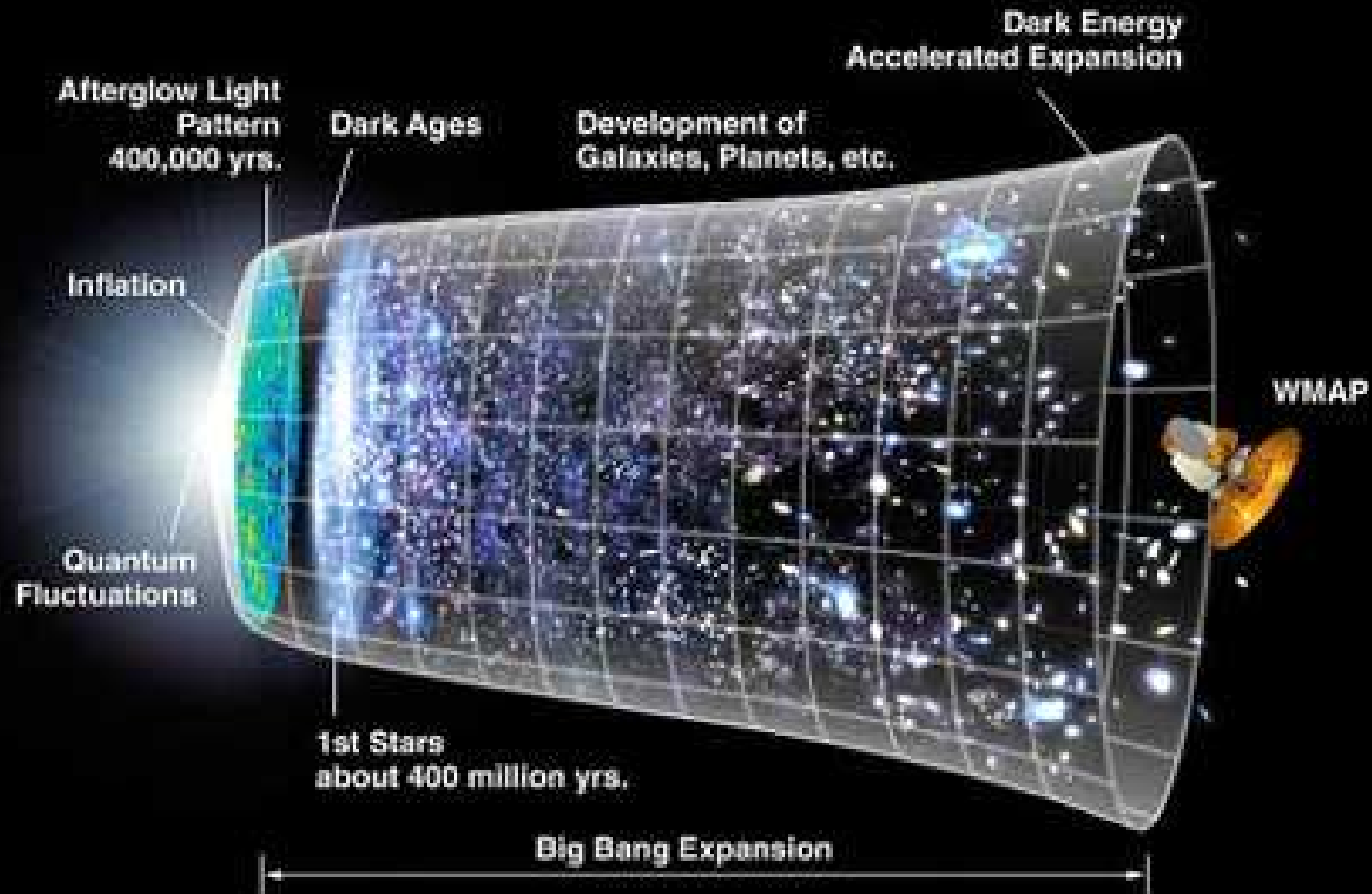

4.560.000.000 years

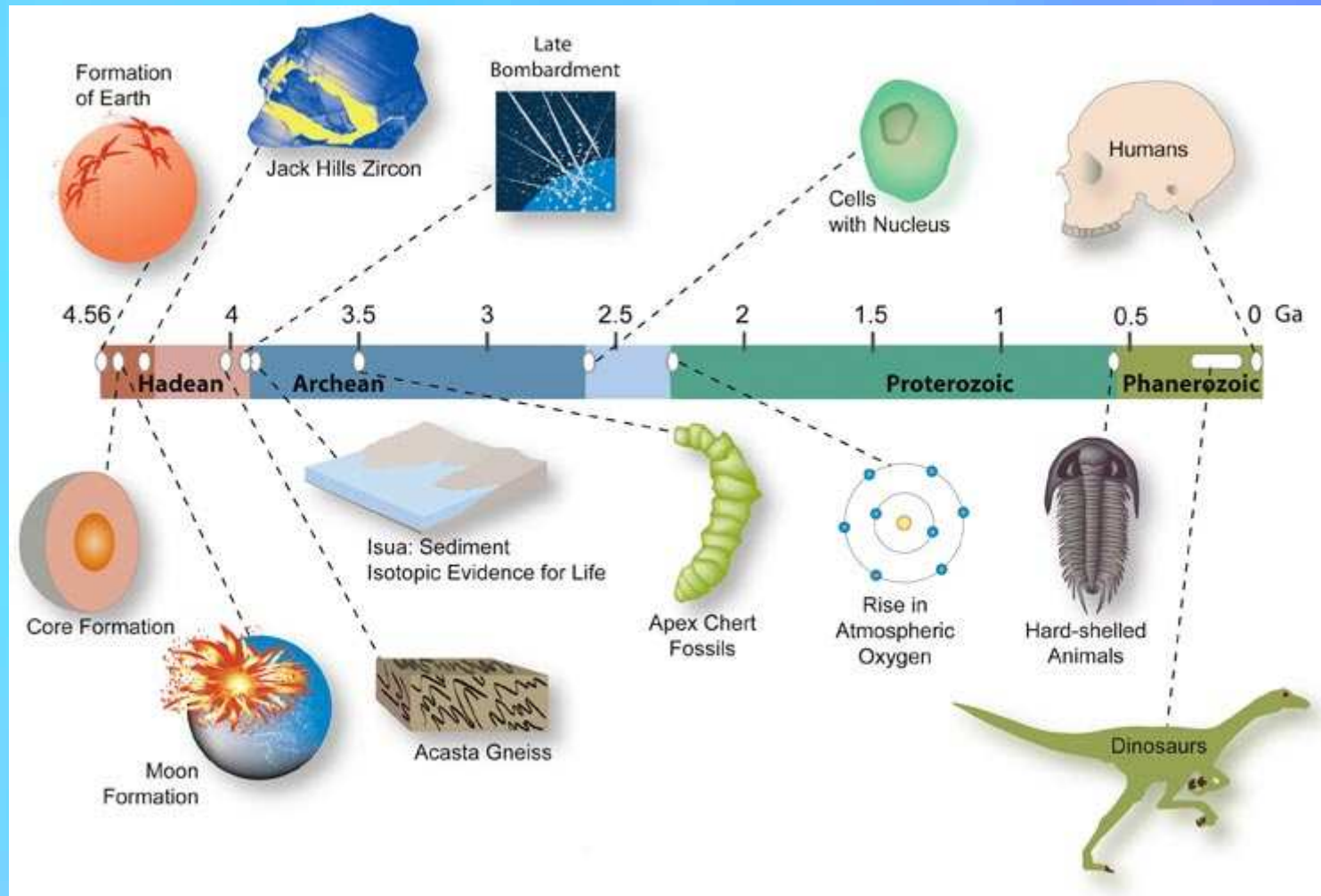

4.000.000 years

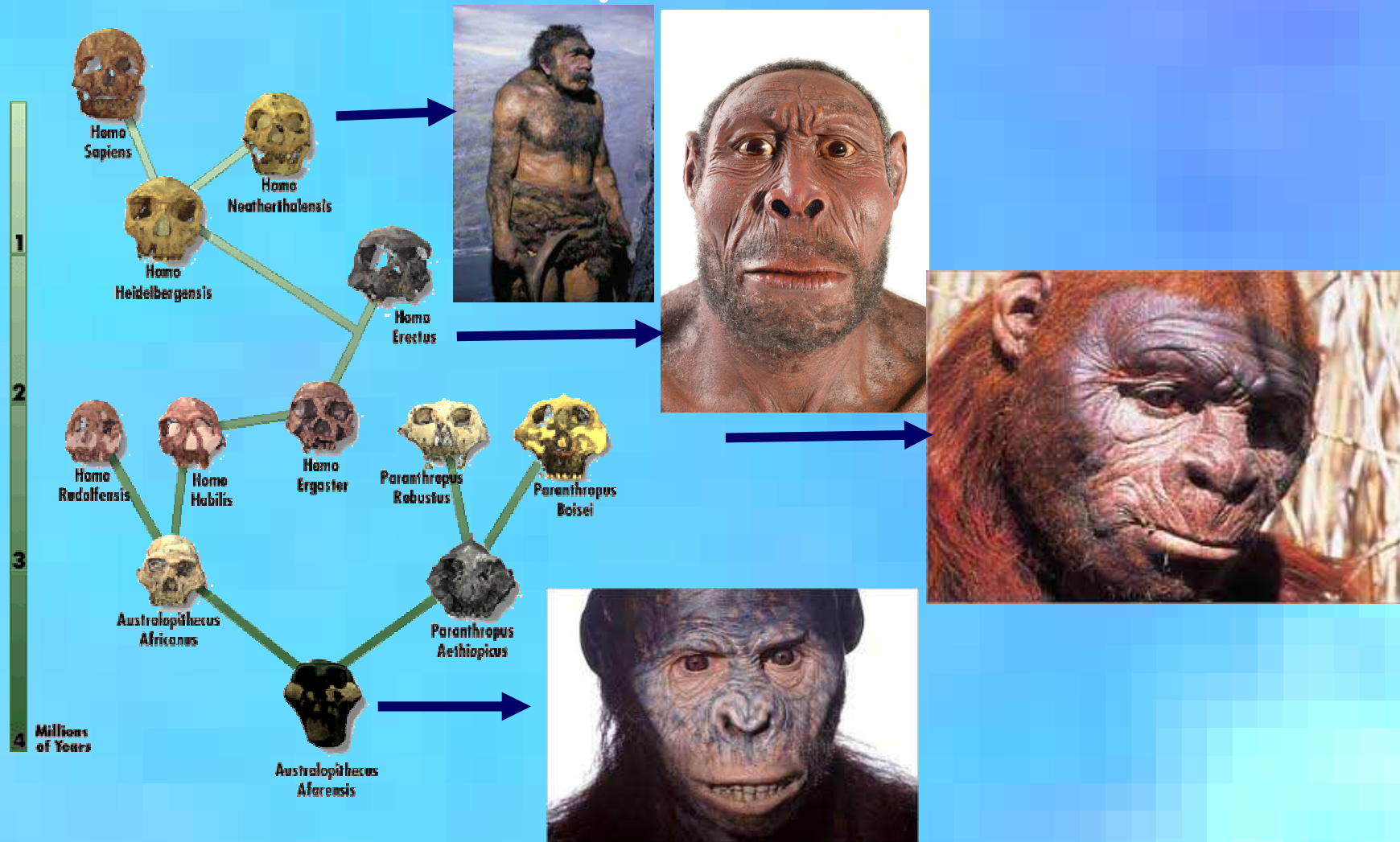

250 years

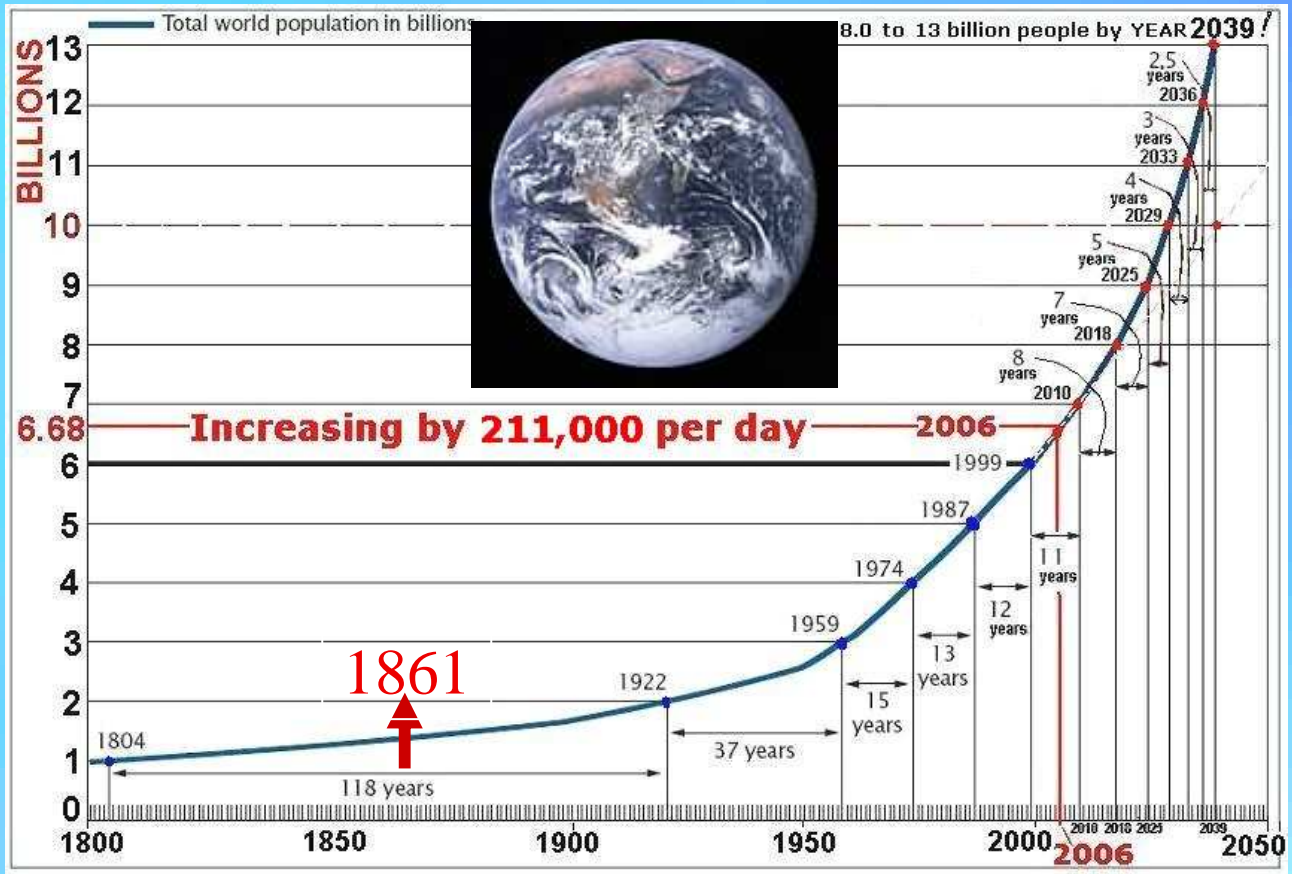

250 years

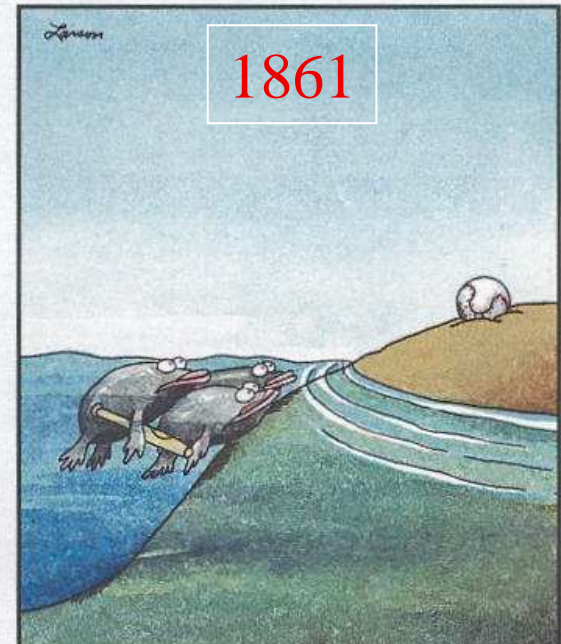
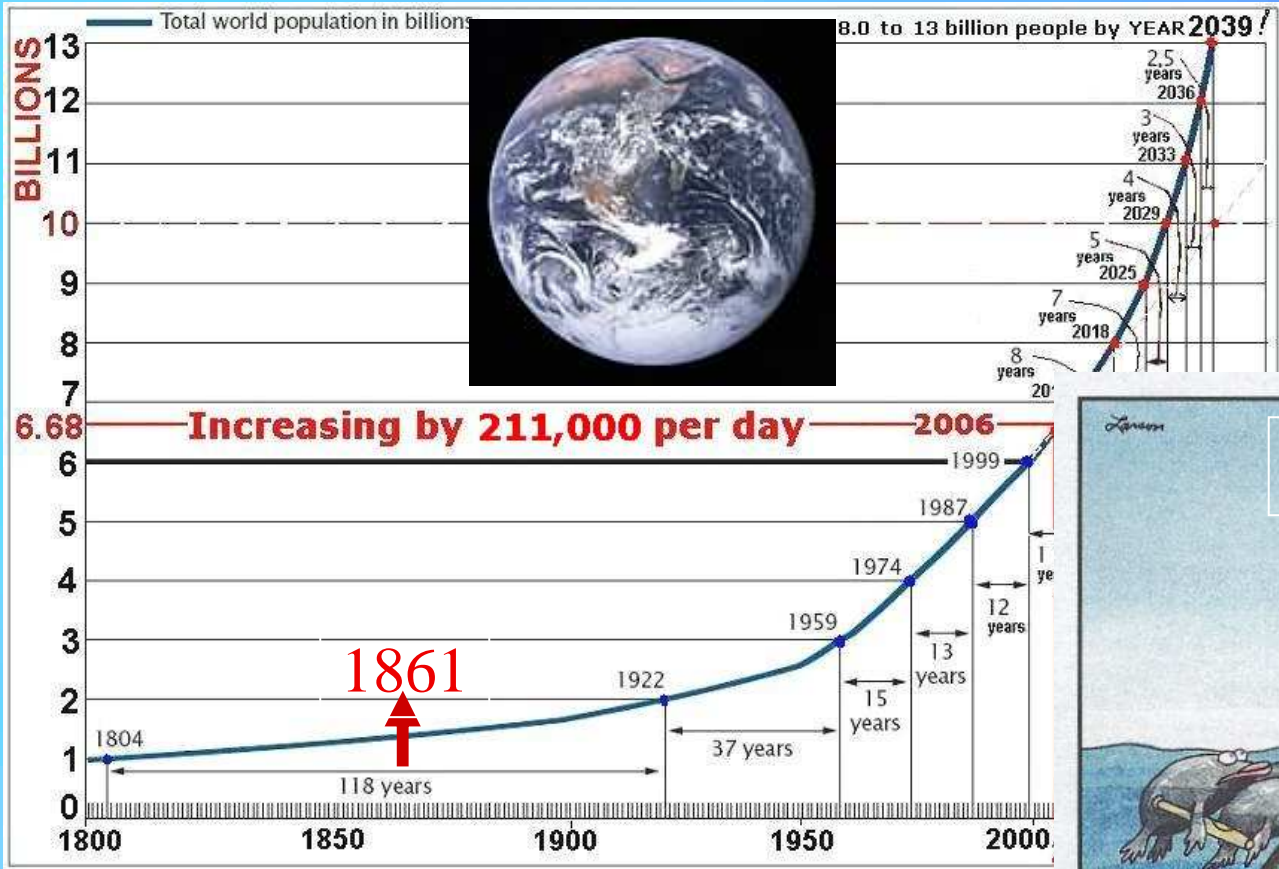

Great moments in evolution

Before
1861

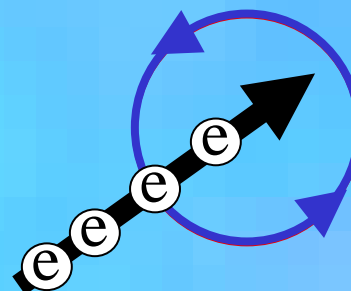
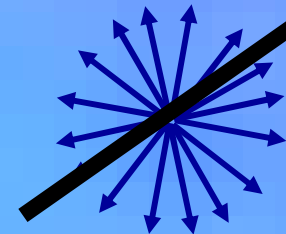
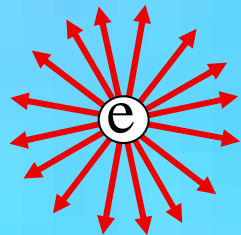

1861

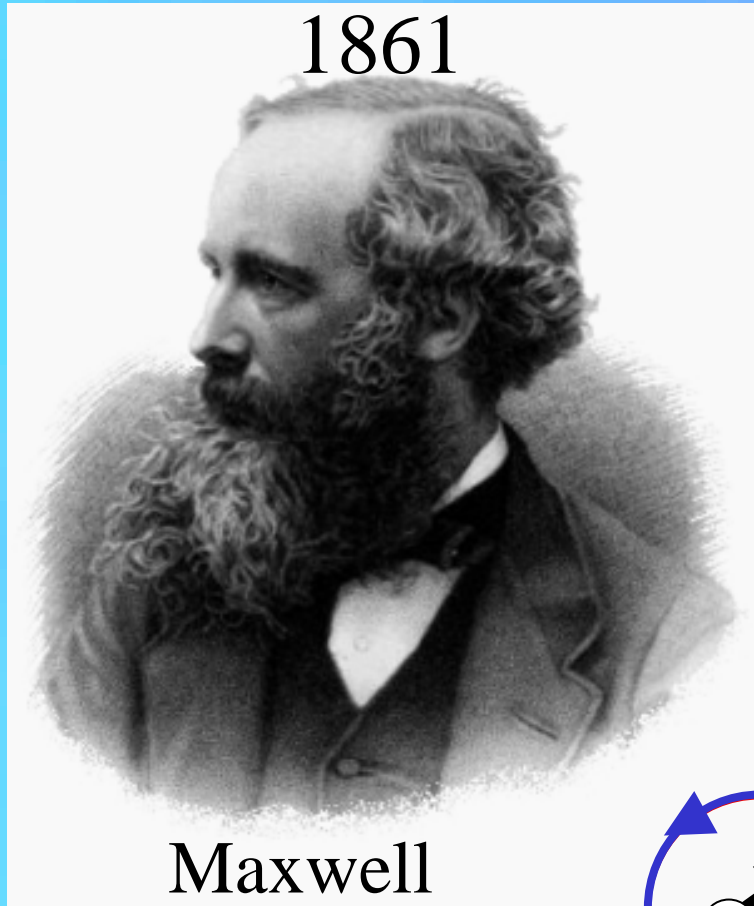

Maxwell

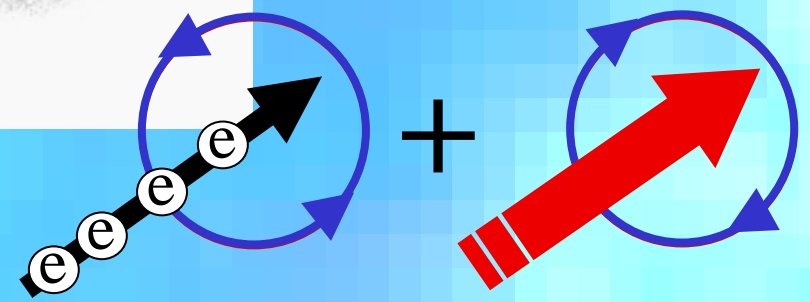
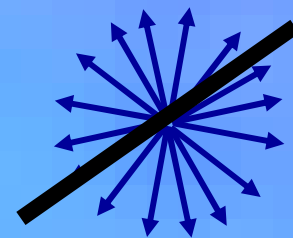
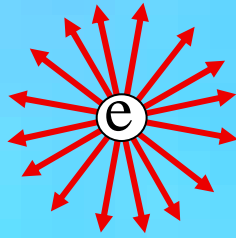

1861

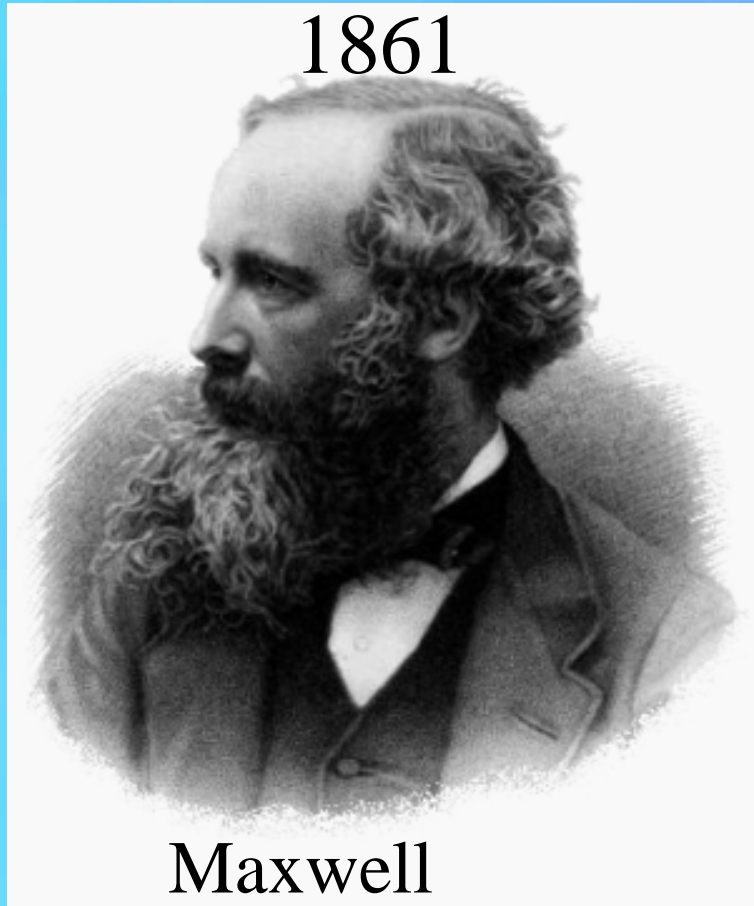

Maxwell

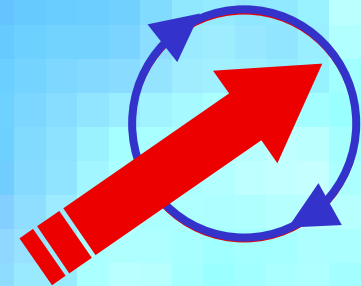
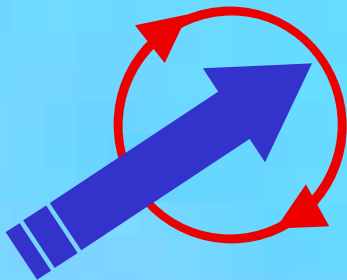
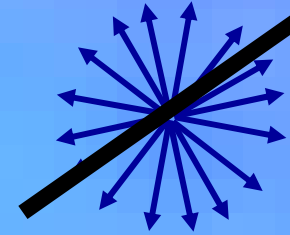
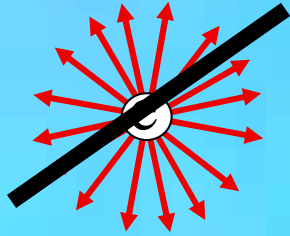

1861

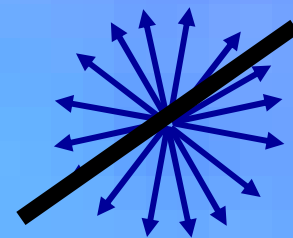
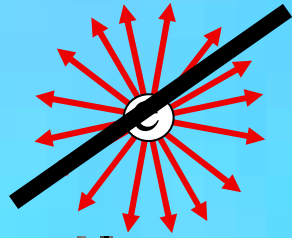

λ

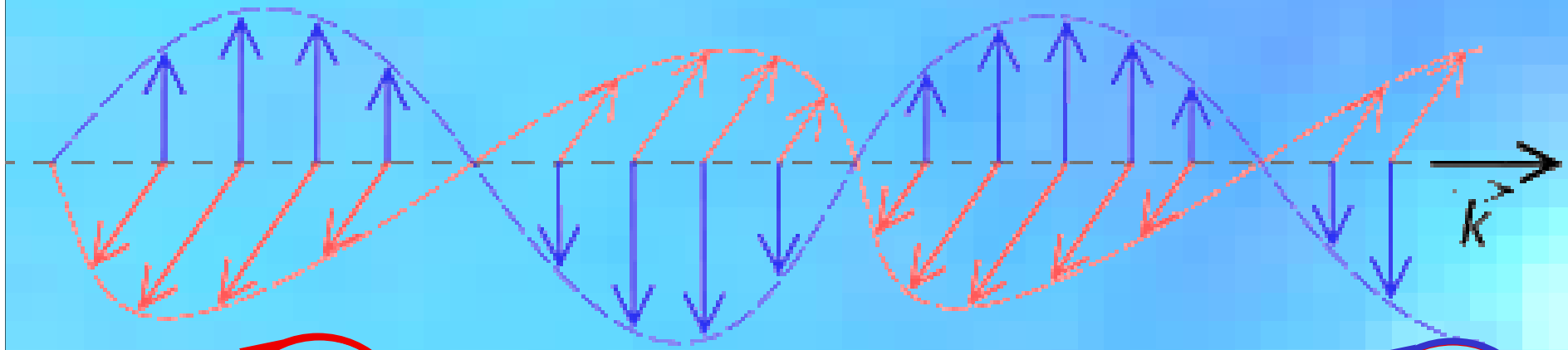

LIGHT!!



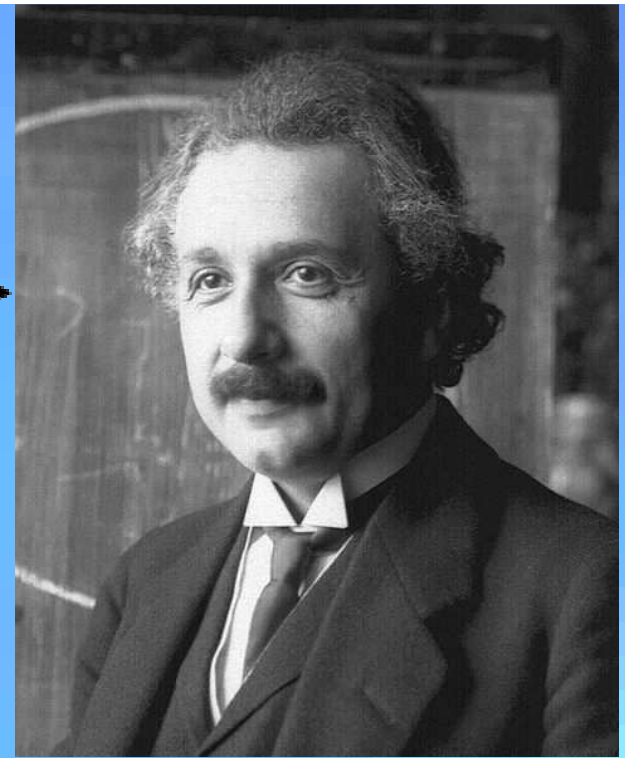
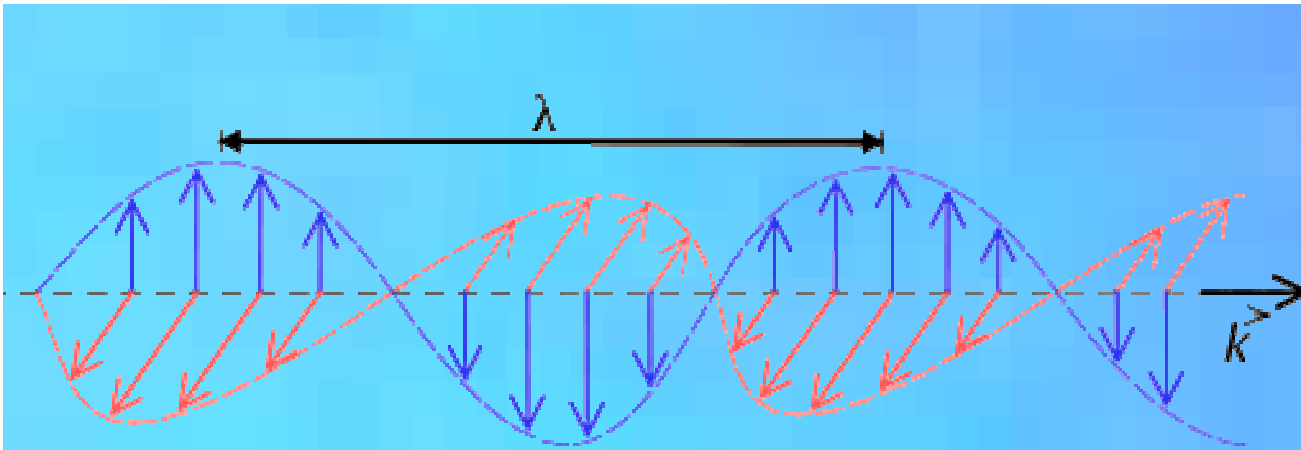

LIGHT!!

1905

Special Relativity

Albert Einstein: *"The special theory of relativity owes its origins to Maxwell's equations of the electromagnetic field."*

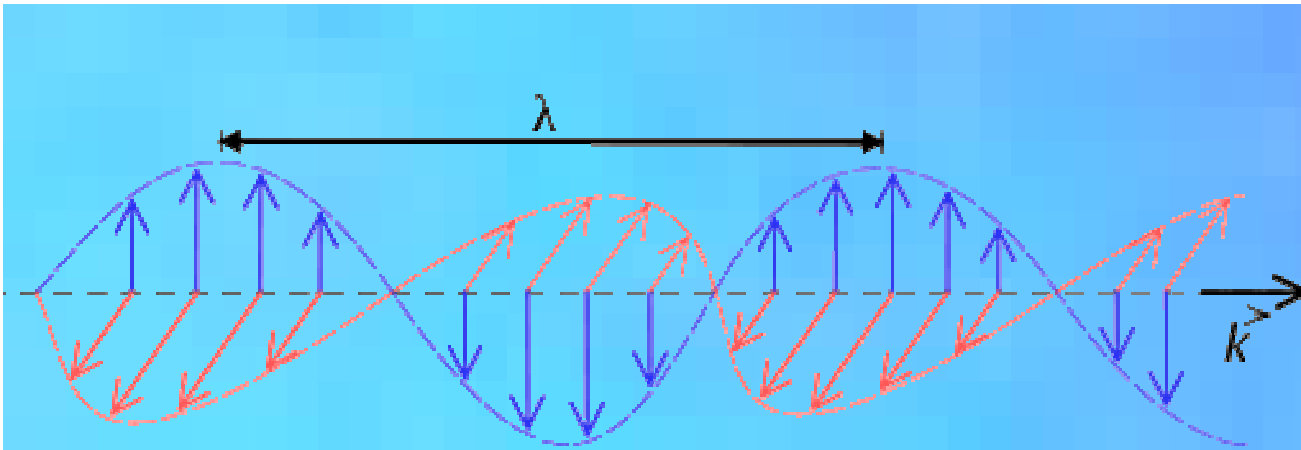

LIGHT!!

Special Relativity

Quantum Theory

1906

Max Planck: "*Maxwell achieved greatness unequalled*"

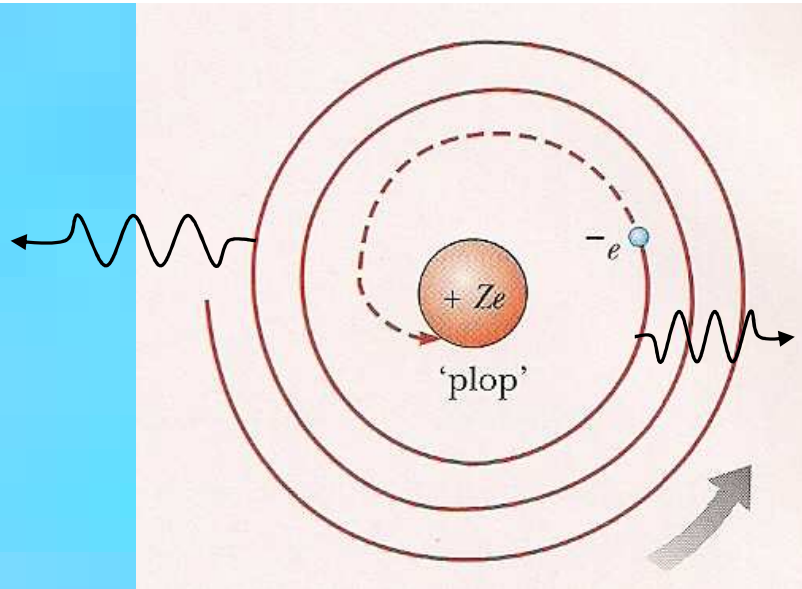

How can we understand the structure of atoms and molecules?

Classical physics doesn't work!

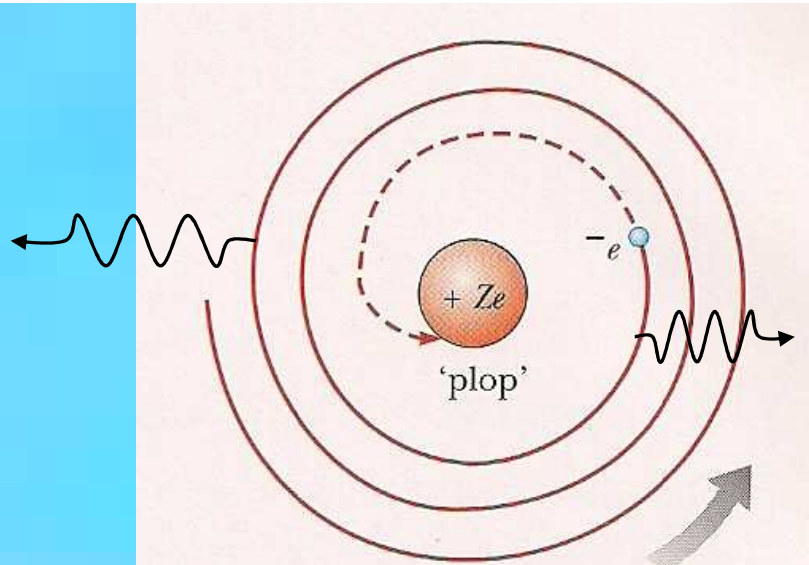

Bohr

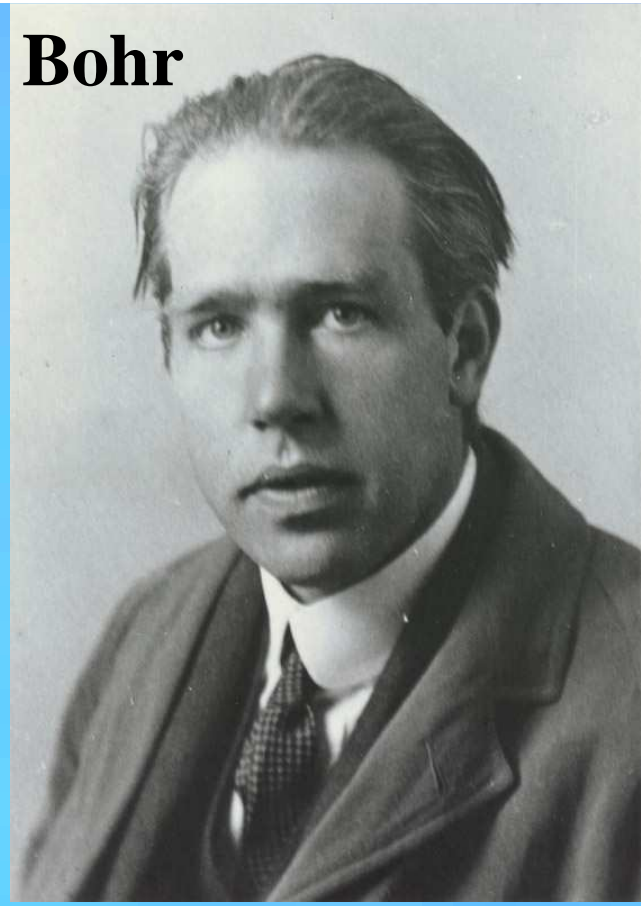

	$m=0$	$m=1$	$m=2$	
$n=1$ $l=0$				$\hat{H}\Psi = i\hbar \frac{\partial \Psi}{\partial t}$ $\hat{H}\psi = E\psi$
$n=2$ $l=0$				
$n=2$ $l=1$				
$n=3$ $l=0$				
$n=3$ $l=1$				
$n=3$ $l=2$				

Quantum Mechanics

Pauli: two electrons cannot be in the same state

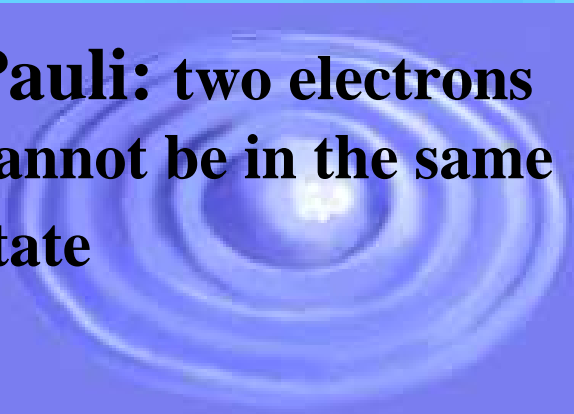

Quantum theory



Quantum theory

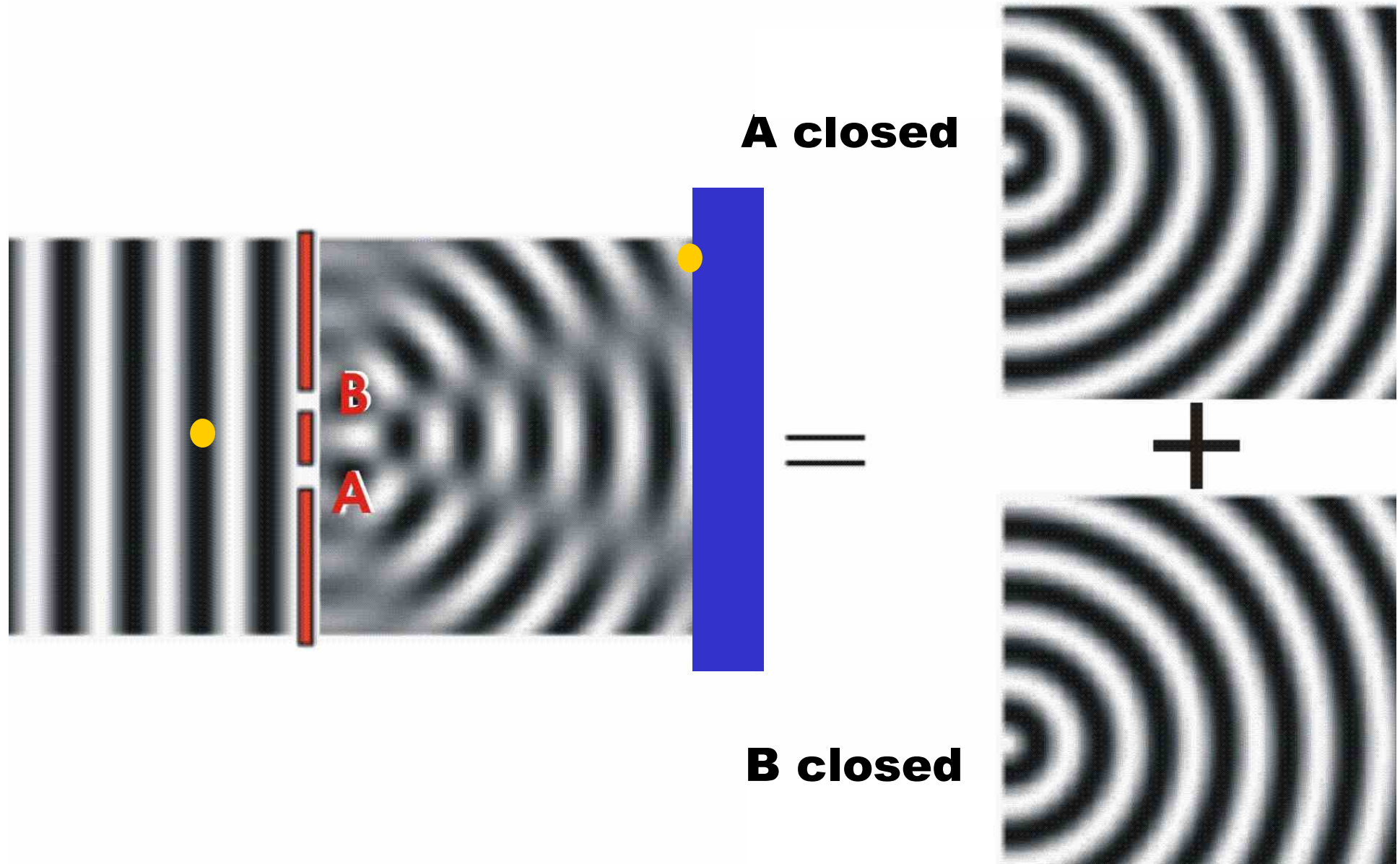

Quantum theory

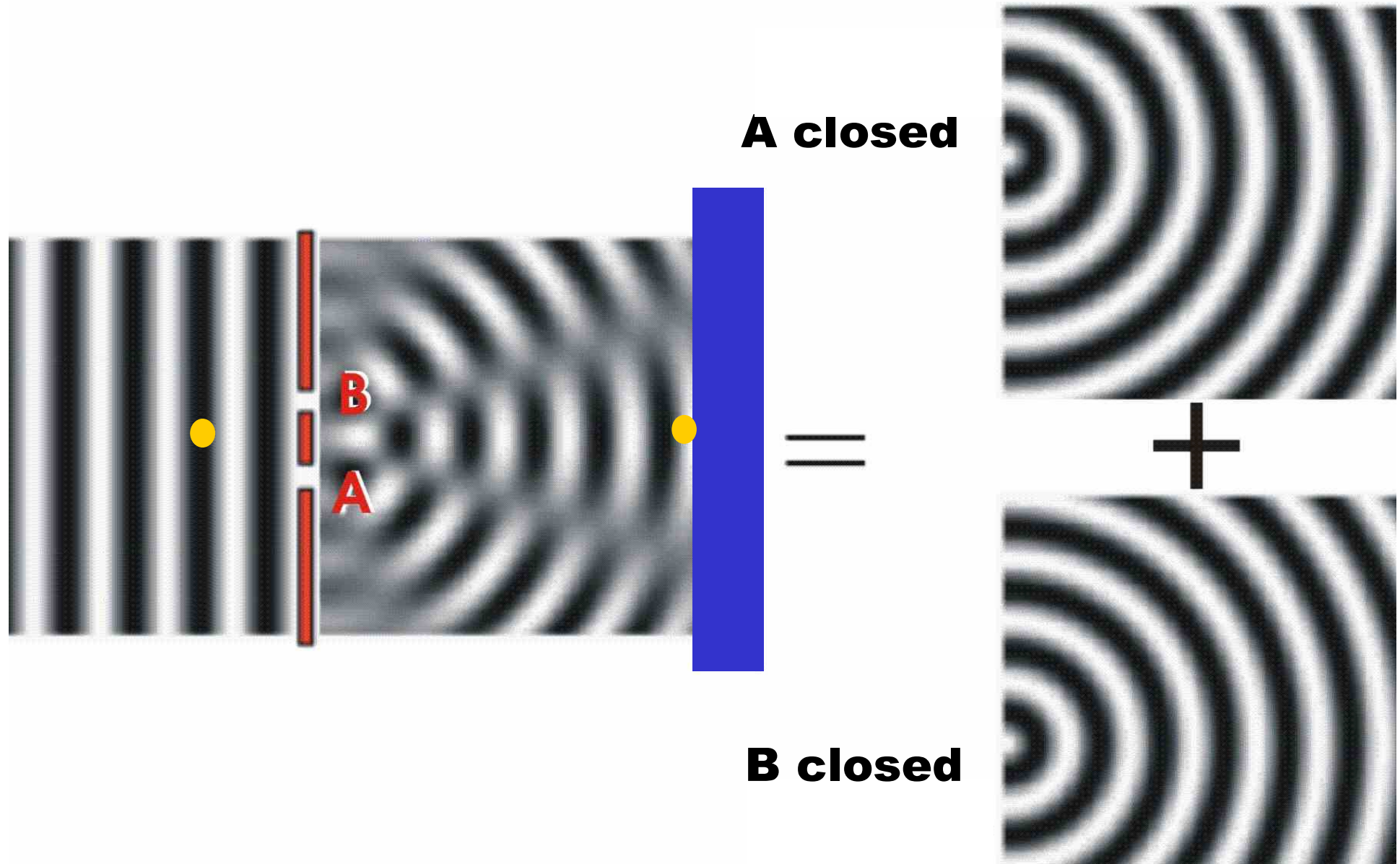

Quantum theory

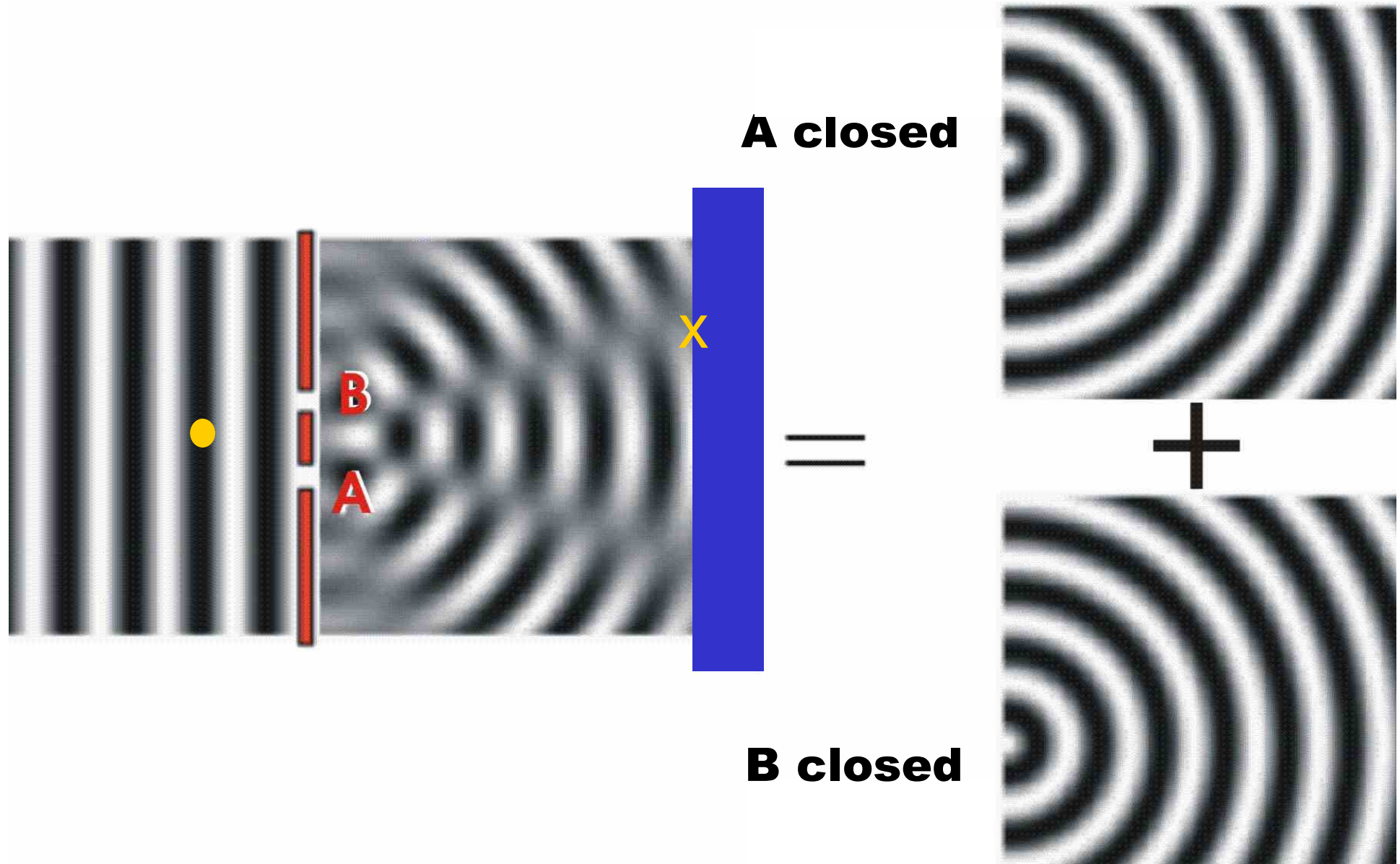

Quantum theory

phase

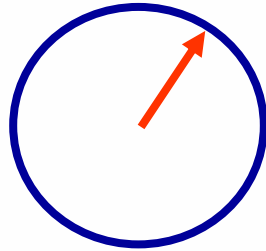

A closed

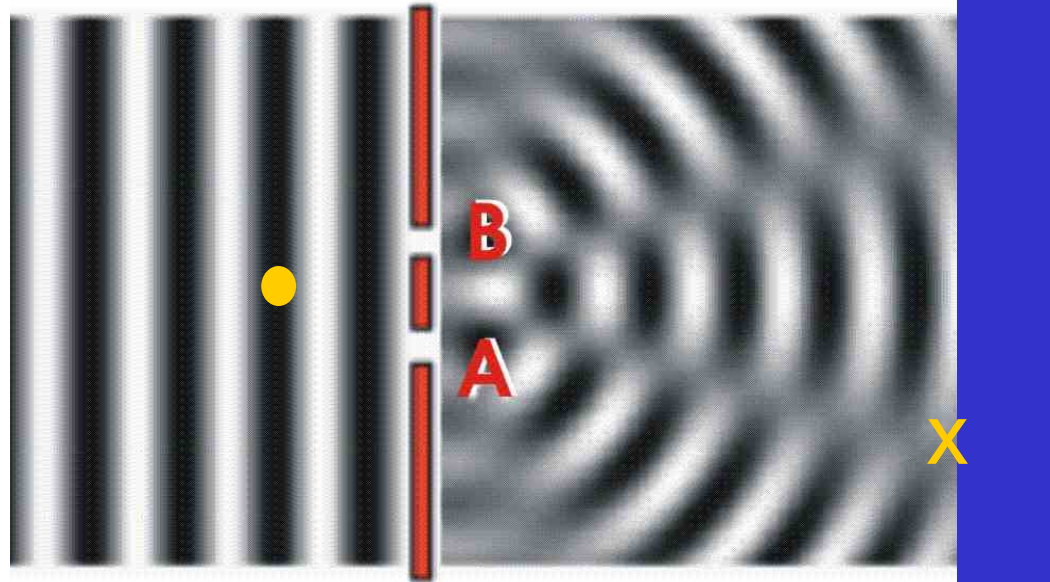
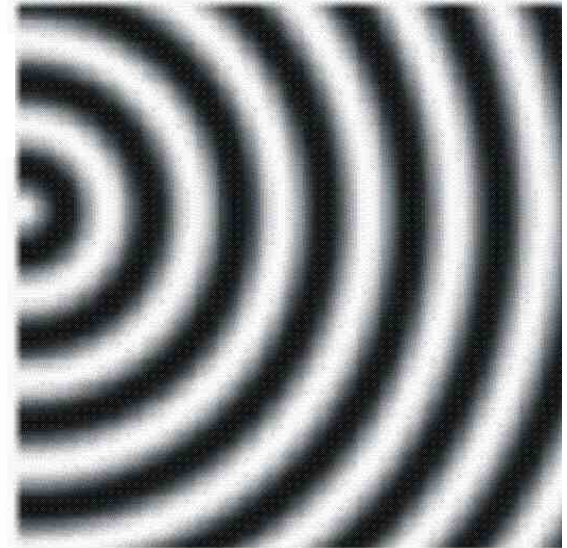

=

+



$$\Psi_{\bullet} = |A\rangle_{\bullet} + \bigcirc_{\nearrow} |B\rangle_{\bullet}$$

B closed

Quantum theory

Quantum superpositions
in position, time, or polarisation

Photons

position superposition

$$\Psi = |L\rangle + \uparrow |R\rangle$$

Quantum interference

$|L\rangle$

$|R\rangle$

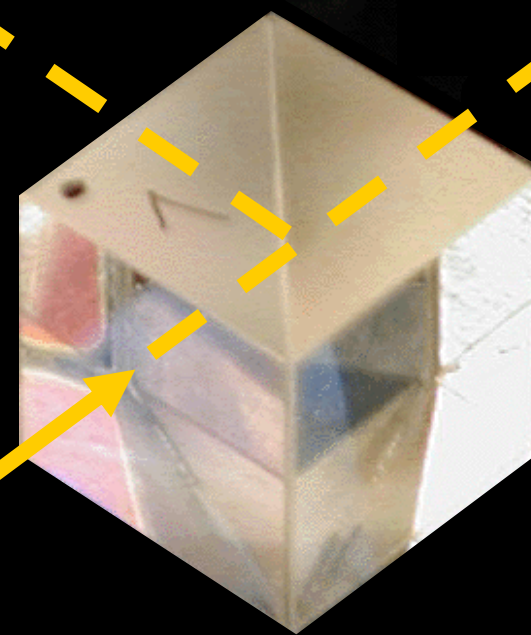

$$\Psi = |L\rangle + \uparrow |R\rangle$$

Quantum interference

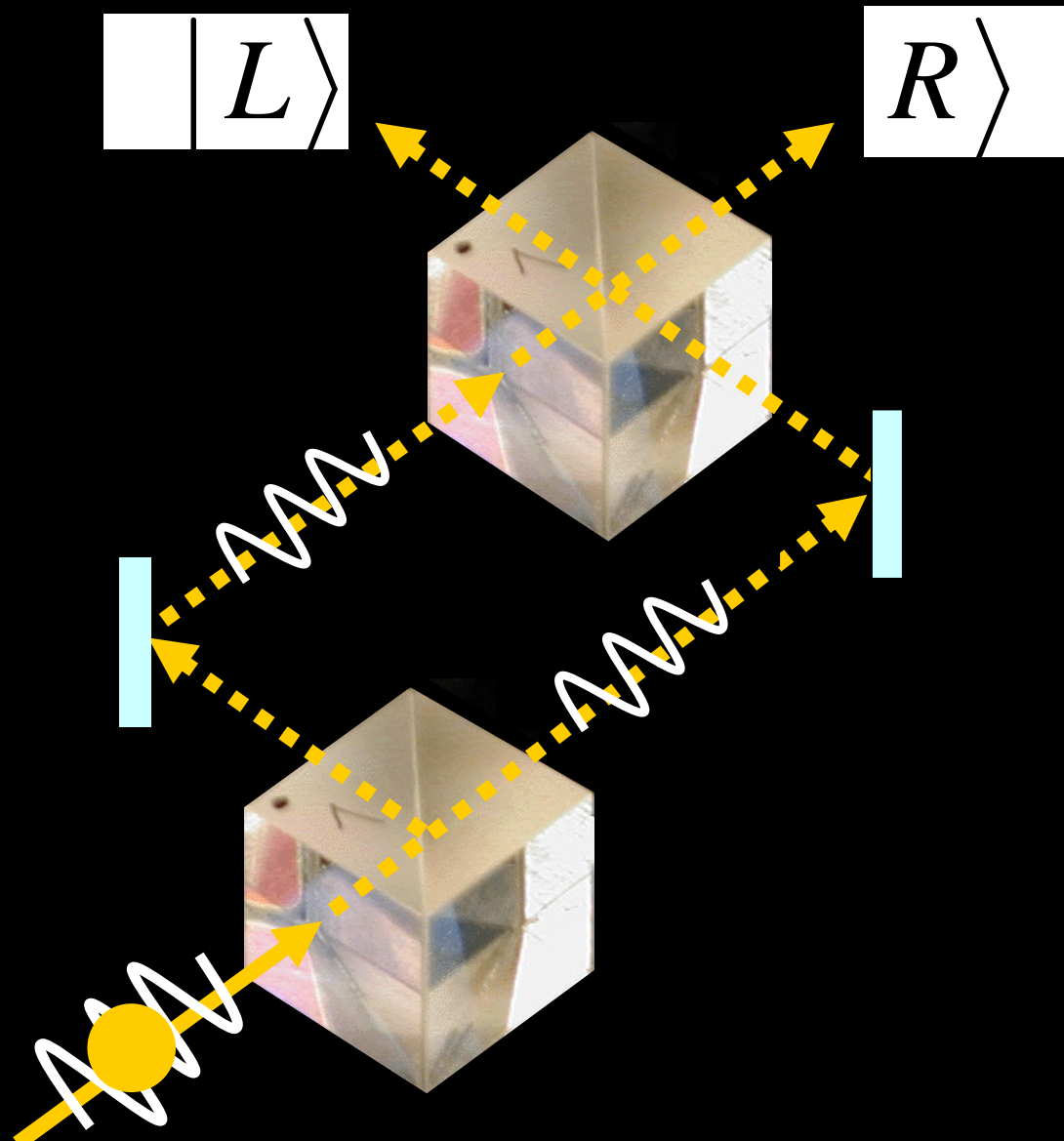

Quantum interference

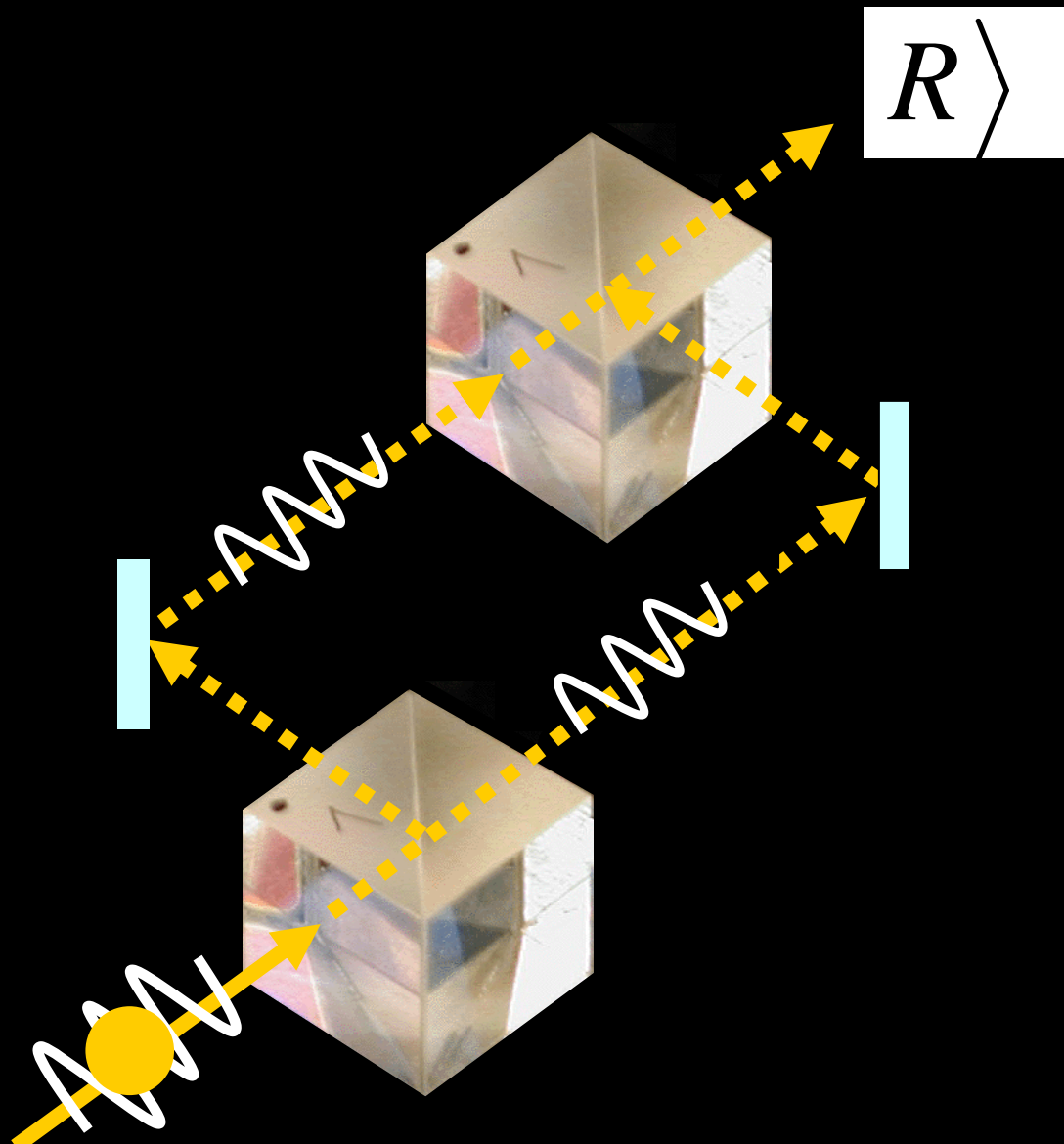

Quantum interference

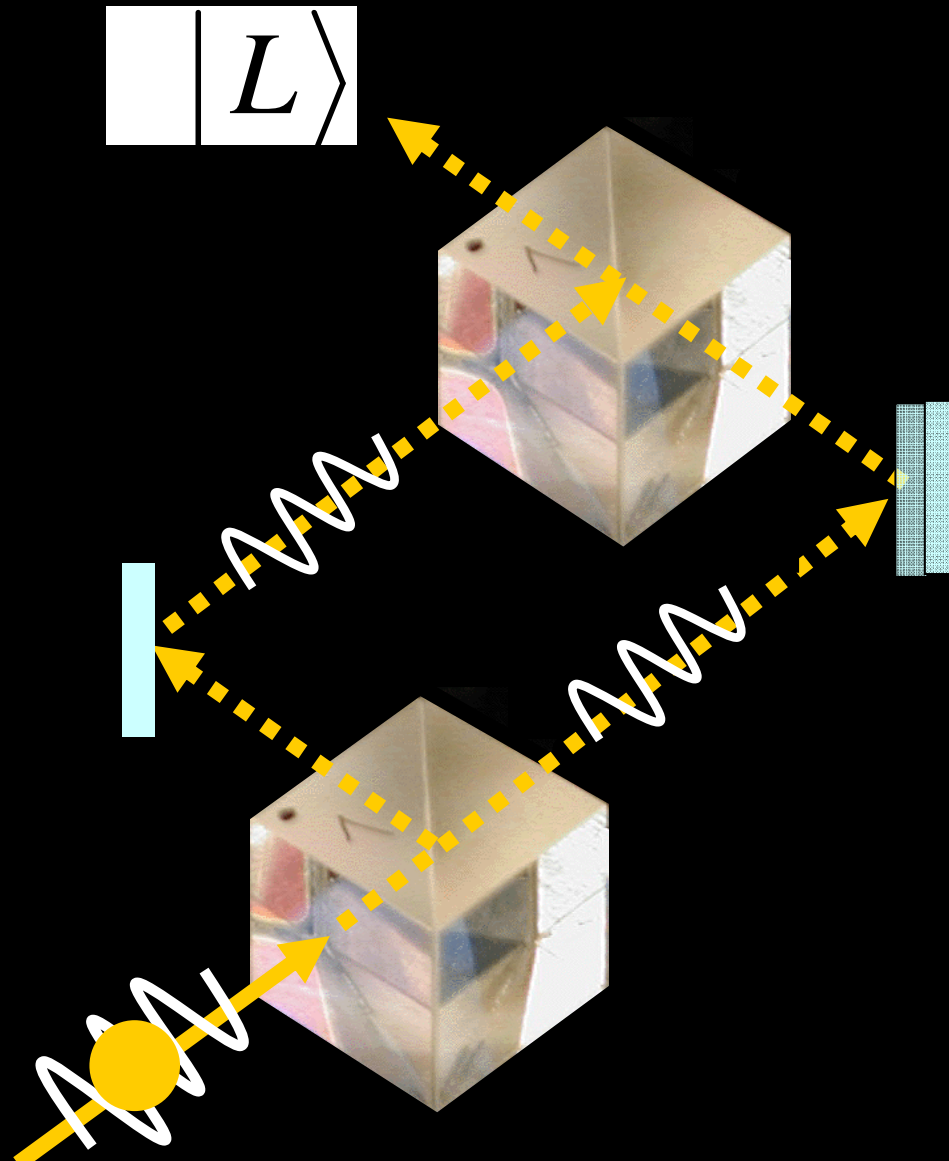

Quantum theory

Quantum superposition
in position, time, or polarisation

Photons

polarisation superposition

$$\Psi = |H\rangle + \uparrow |V\rangle$$

Quantum measurement

Chance
is a law of nature

$|H\rangle$

$|V\rangle$

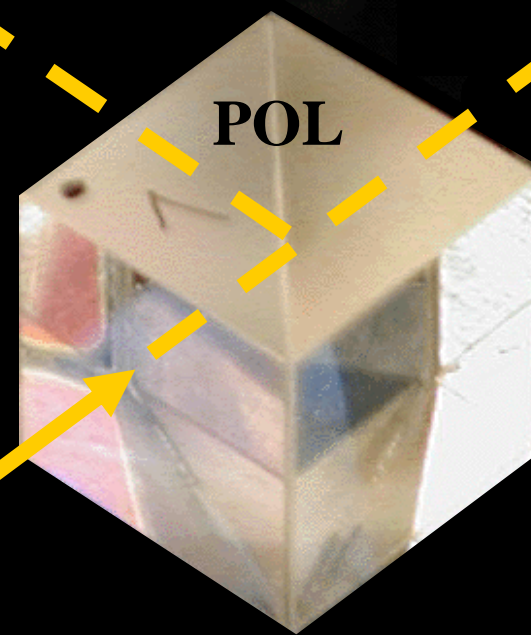

$$\Psi_{\bullet} = |H\rangle_{\bullet} + \overset{\uparrow}{\circ} |V\rangle_{\bullet}$$

Quantum measurement

Chance
is a law of nature



Klick

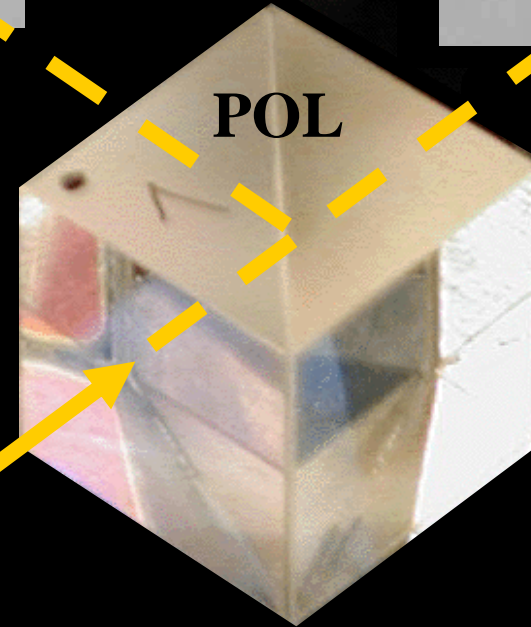

$$\Psi_{\bullet} = |H\rangle_{\bullet} + \overset{\uparrow}{\circ} |V\rangle_{\bullet}$$

Quantum measurement

Chance
is a law of nature

$|H\rangle$

$|V\rangle$

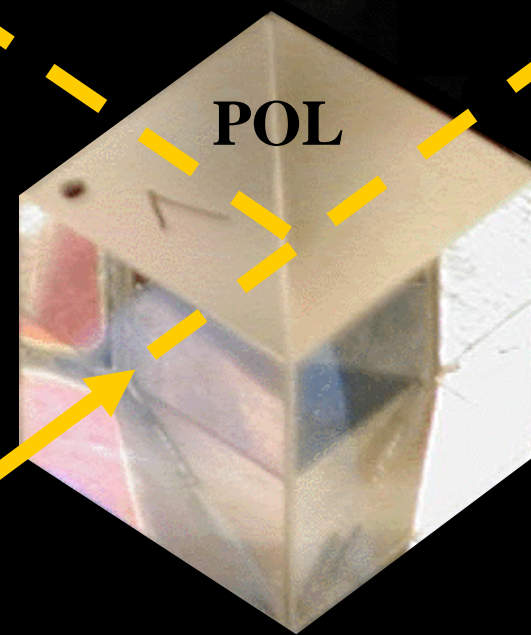

Ψ can not be
measured directly



Quantum measurement



Einstein:

“God does not play dice.”

Bohr:

“Stop telling God what to do!!”

Quantum interference

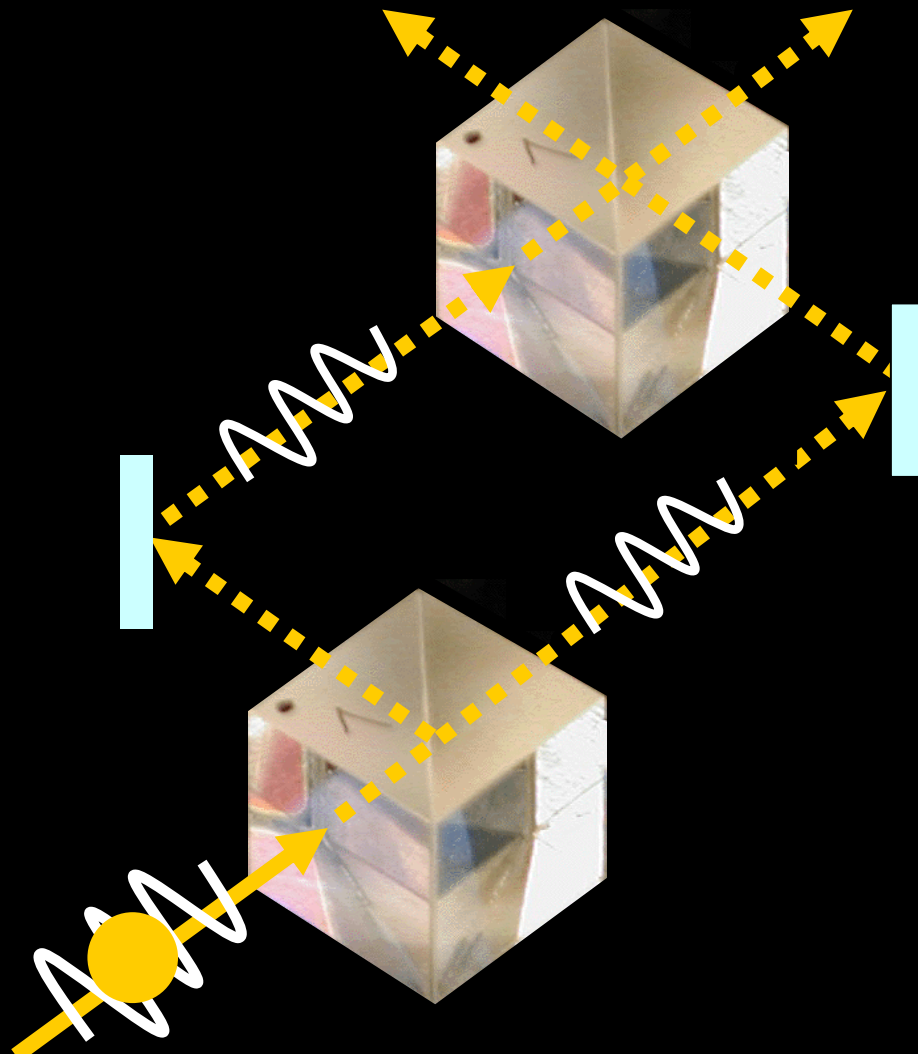

Surfing electron?!?



Quantum entanglement

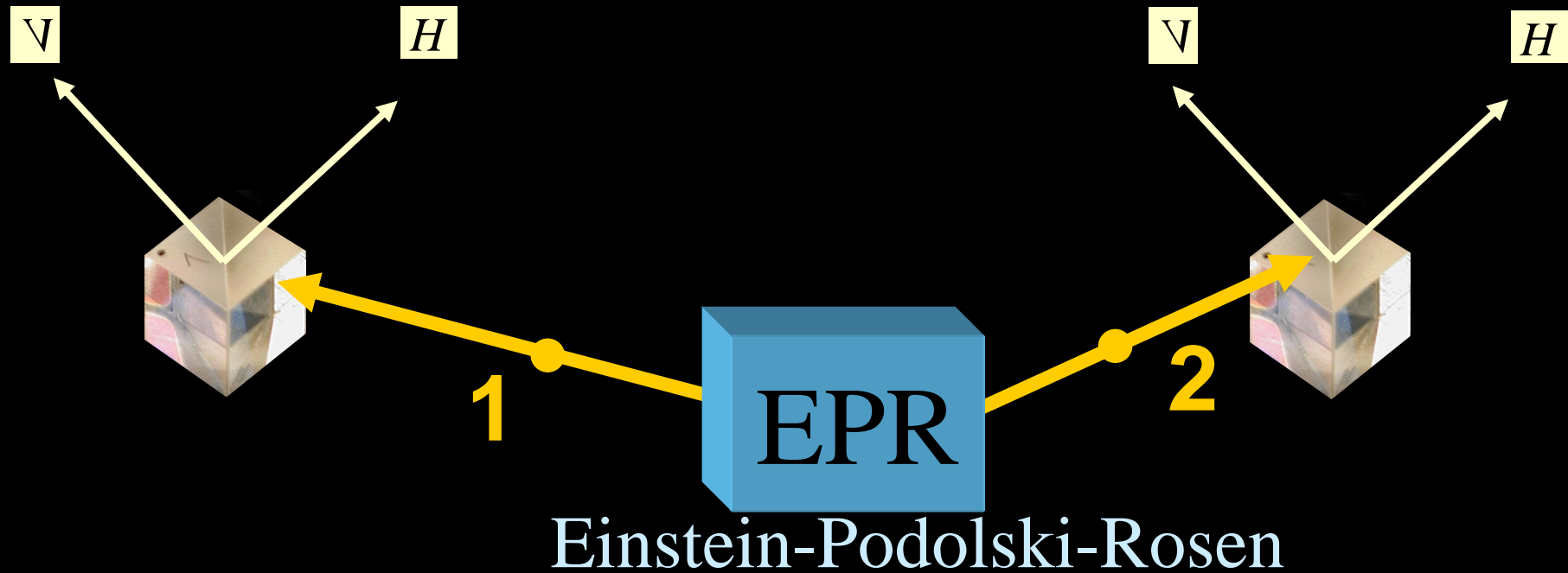

Einstein-Podolski-Rosen

$$\Psi_{12} = |H\rangle_1 |V\rangle_2 + \ominus |V\rangle_1 |H\rangle_2$$

Quantum entanglement

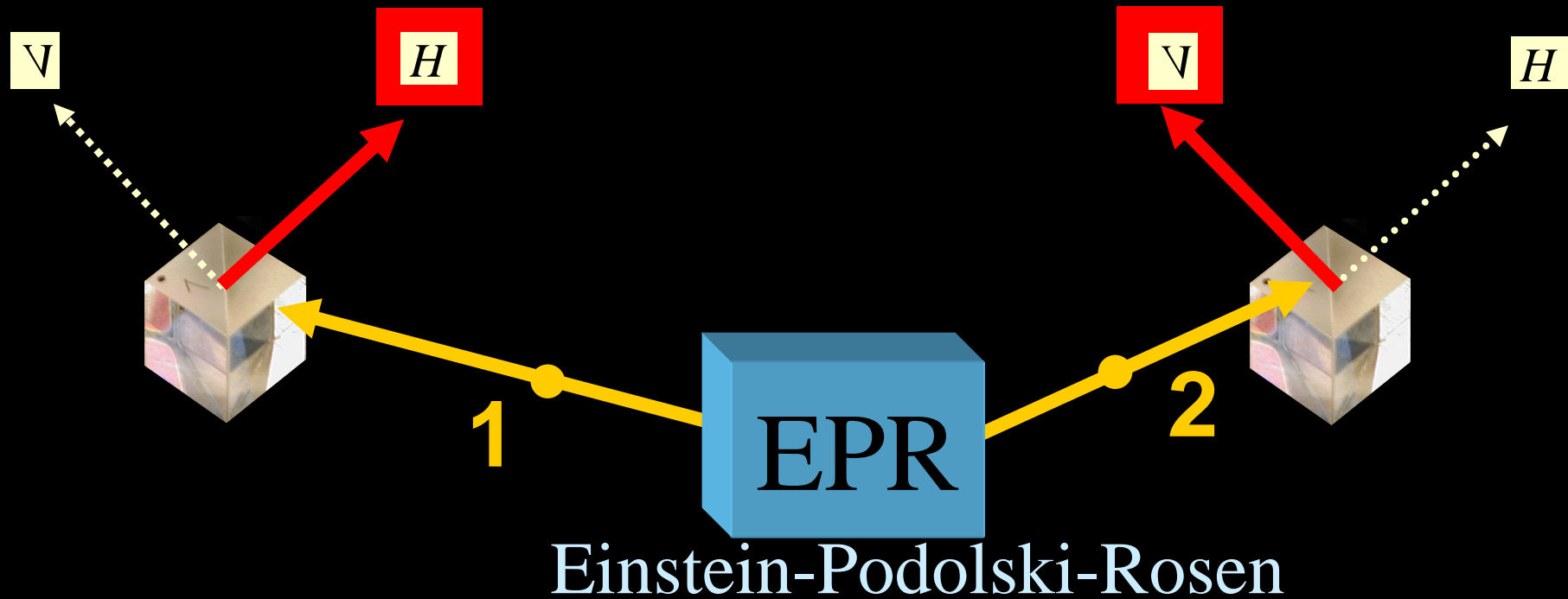

$$\Psi_{12} = |H\rangle_1 |V\rangle_2 + \ominus |V\rangle_1 |H\rangle_2$$

Quantum entanglement

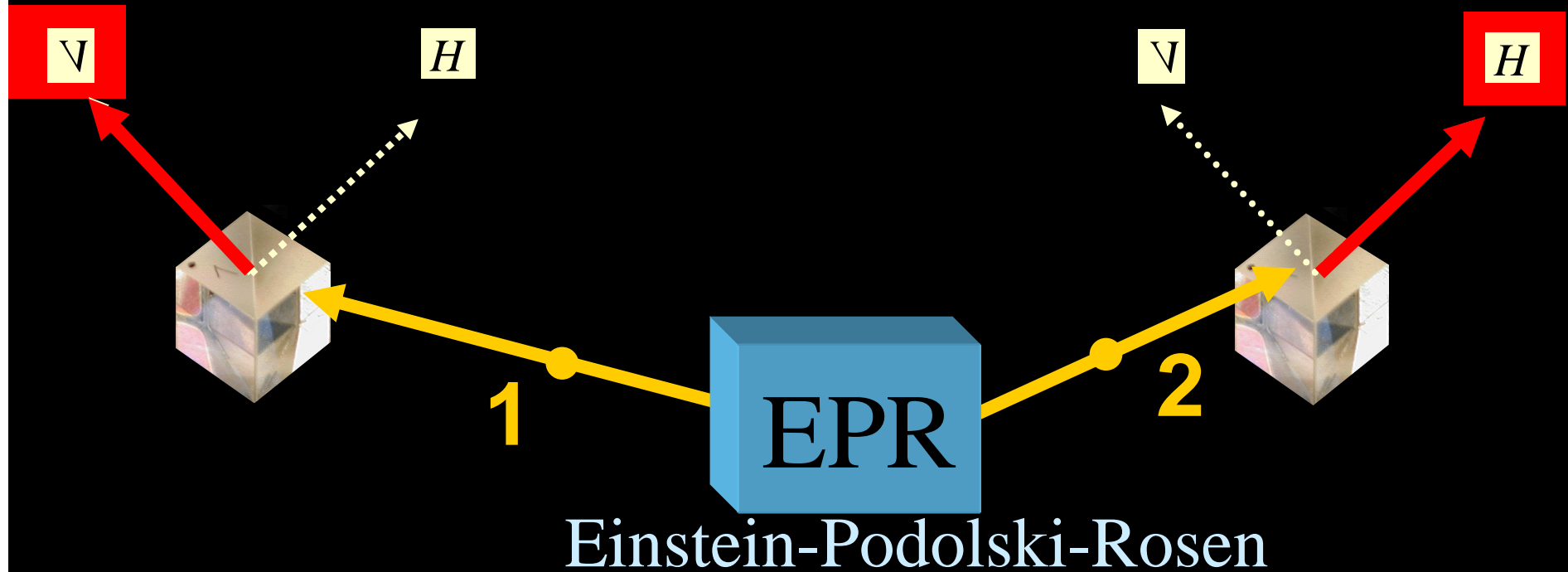

$$\Psi_{12} = |H\rangle_1 |V\rangle_2 - |V\rangle_1 |H\rangle_2$$

Quantum entanglement

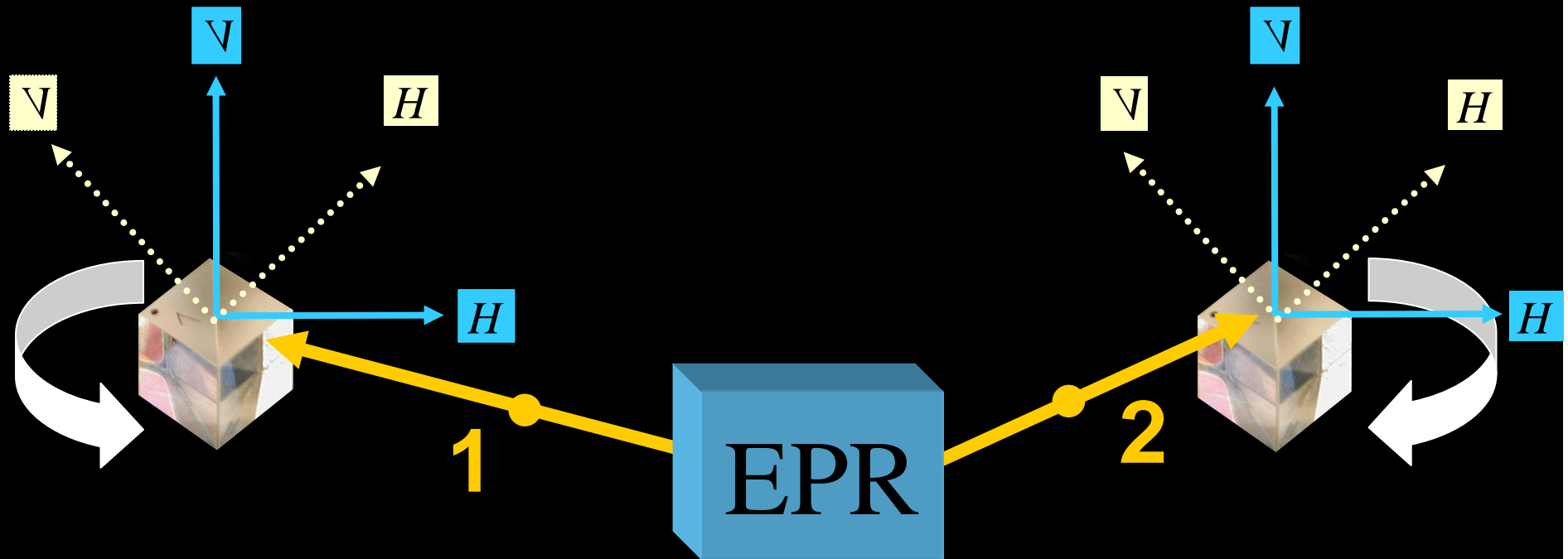

Einstein-Podolski-Rosen

$$\Psi_{12} = |H\rangle_1 |V\rangle_2 - |V\rangle_1 |H\rangle_2$$

Quantum entanglement

Einstein:
"spooky action
at a distance"

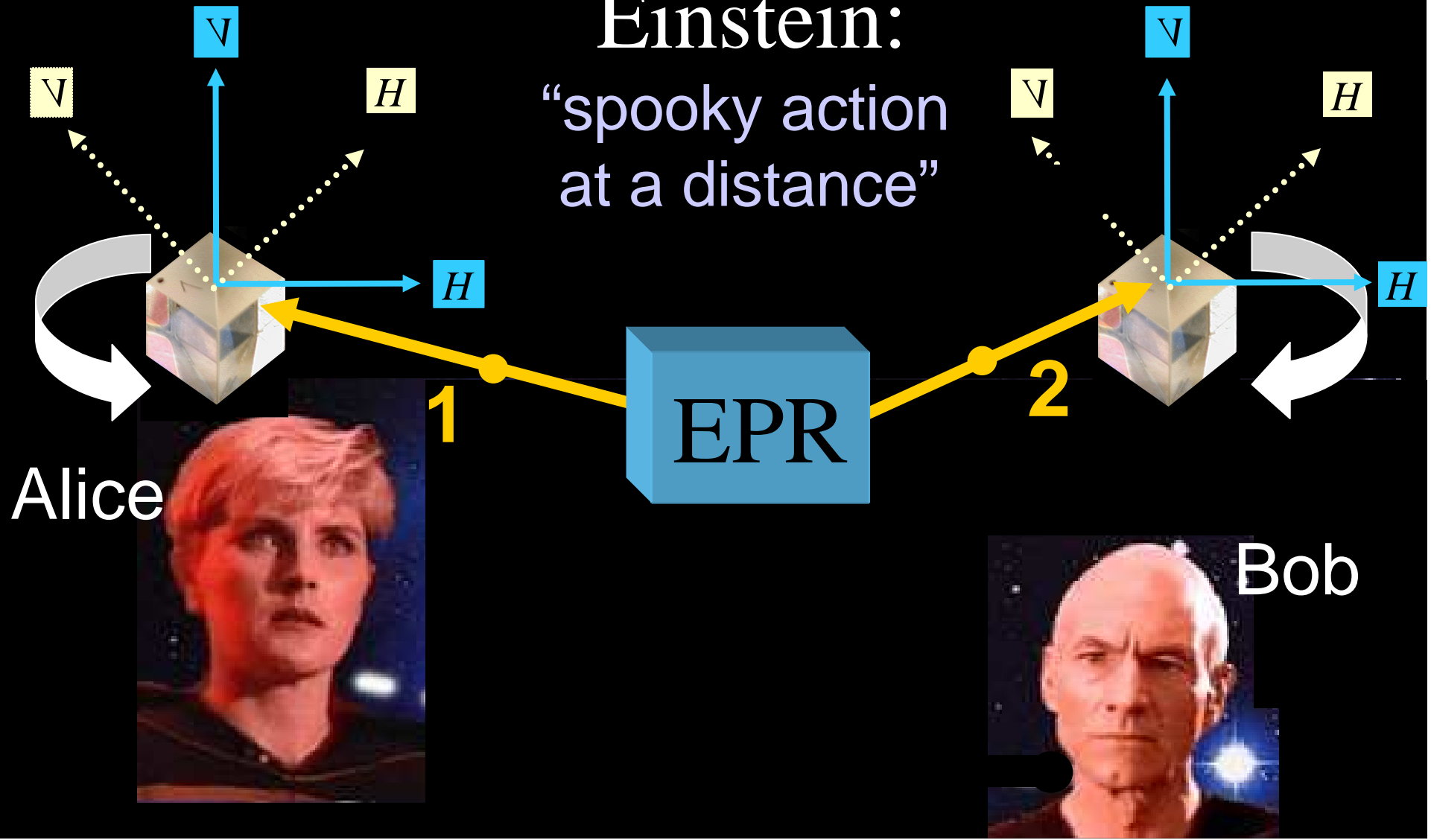

cryptography

Scytale:

Spartans, 400 BC

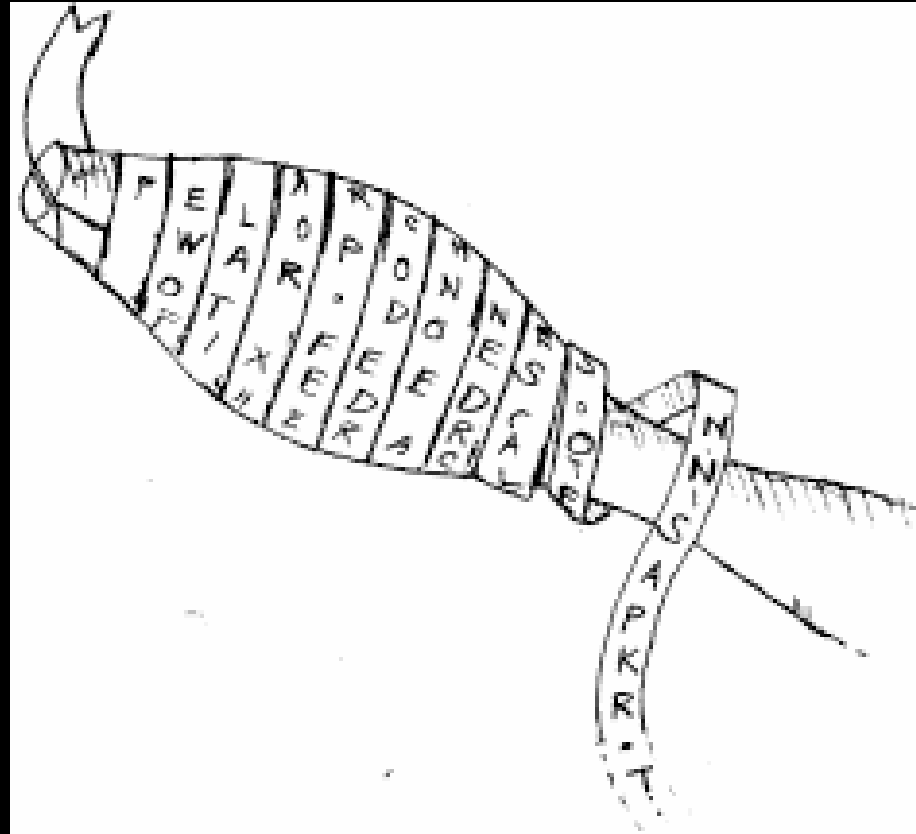

Alice

cryptology

Bob

Message

011010111011101

101001010010010

send

110011101001111

Secret key

101001010010010

110011101001111

011010111011101

$$0+0=0$$

$$0+1=1$$

$$1+0=1$$

$$1+1=0$$

Quantum entanglement

V

1



2

H

$$\Psi_{12} = |H\rangle_1 |V\rangle_2 - |V\rangle_1 |H\rangle_2$$

Quantum cryptography



MagiQ QPN
QPN datasheet



QPNTM Research
QPN datasheet

Presenting the **first**
commercial quantum
cryptography solutions.

Quantum teleportation

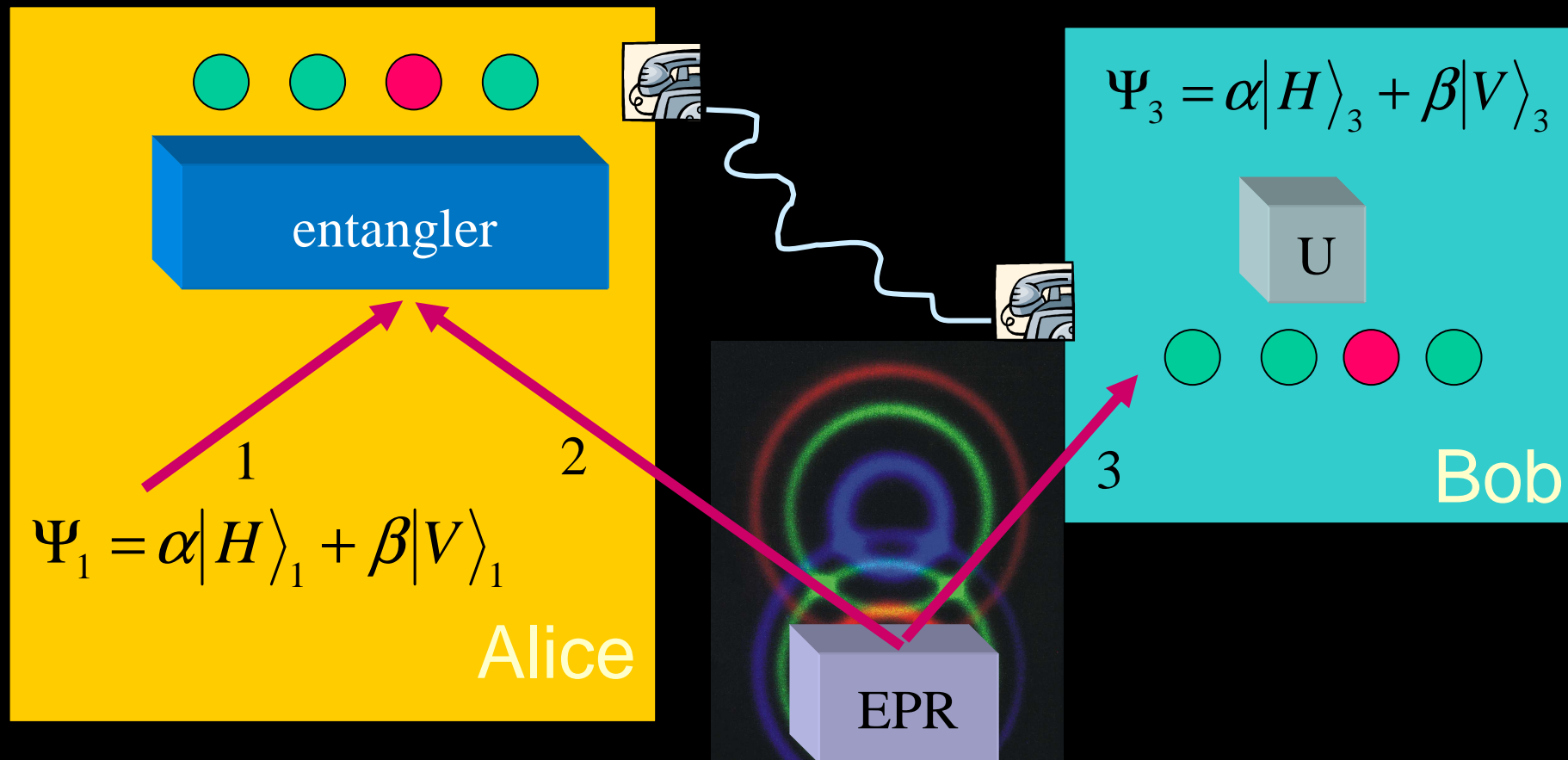

$$\Psi_{23} = |H\rangle_2 |V\rangle_3 - |V\rangle_2 |H\rangle_3$$

Quantum teleportation

Photons

Alice

Entangling

Bob

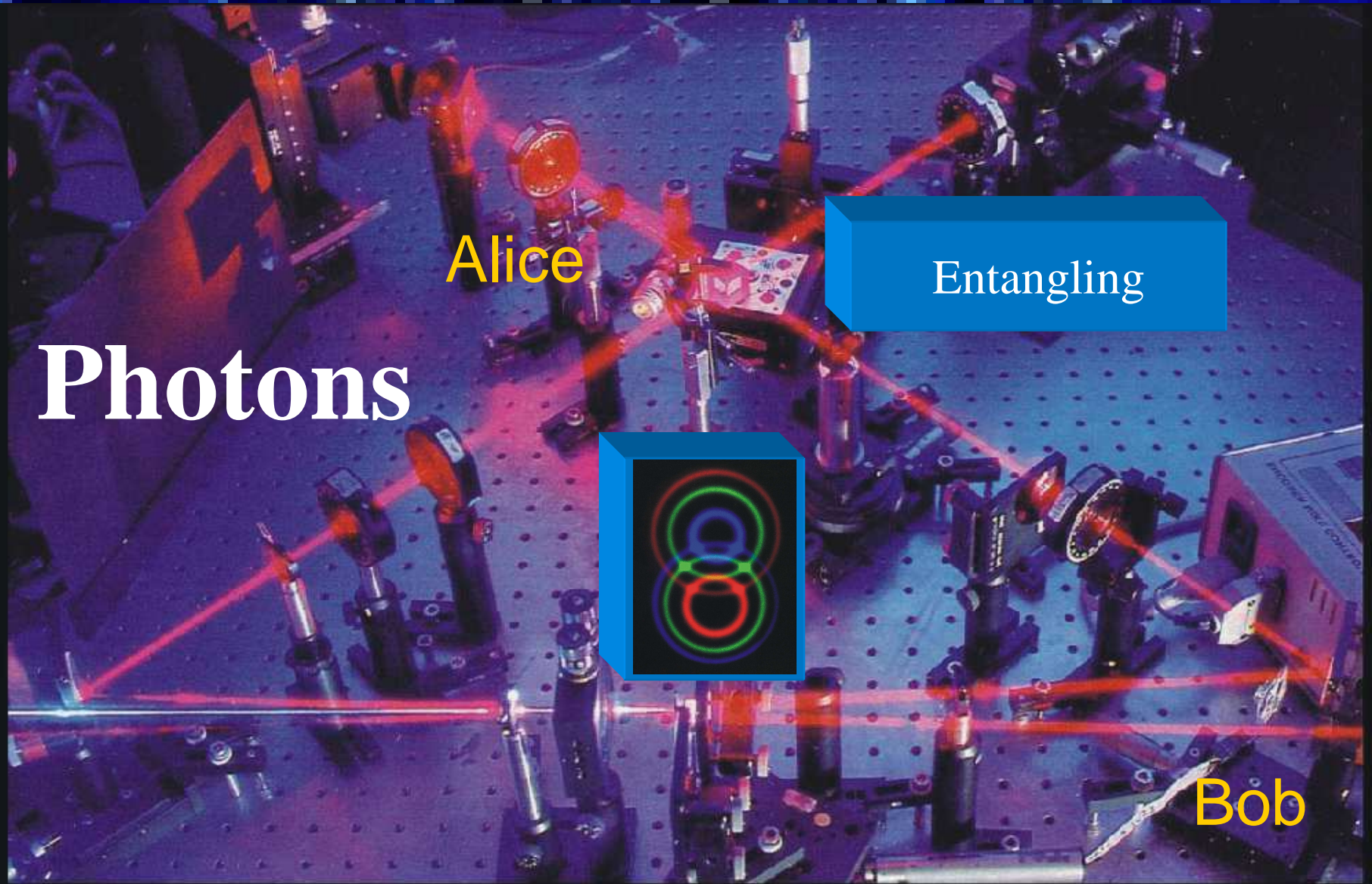
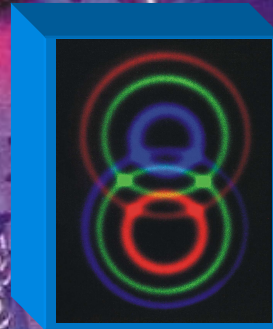

Quantum teleportation

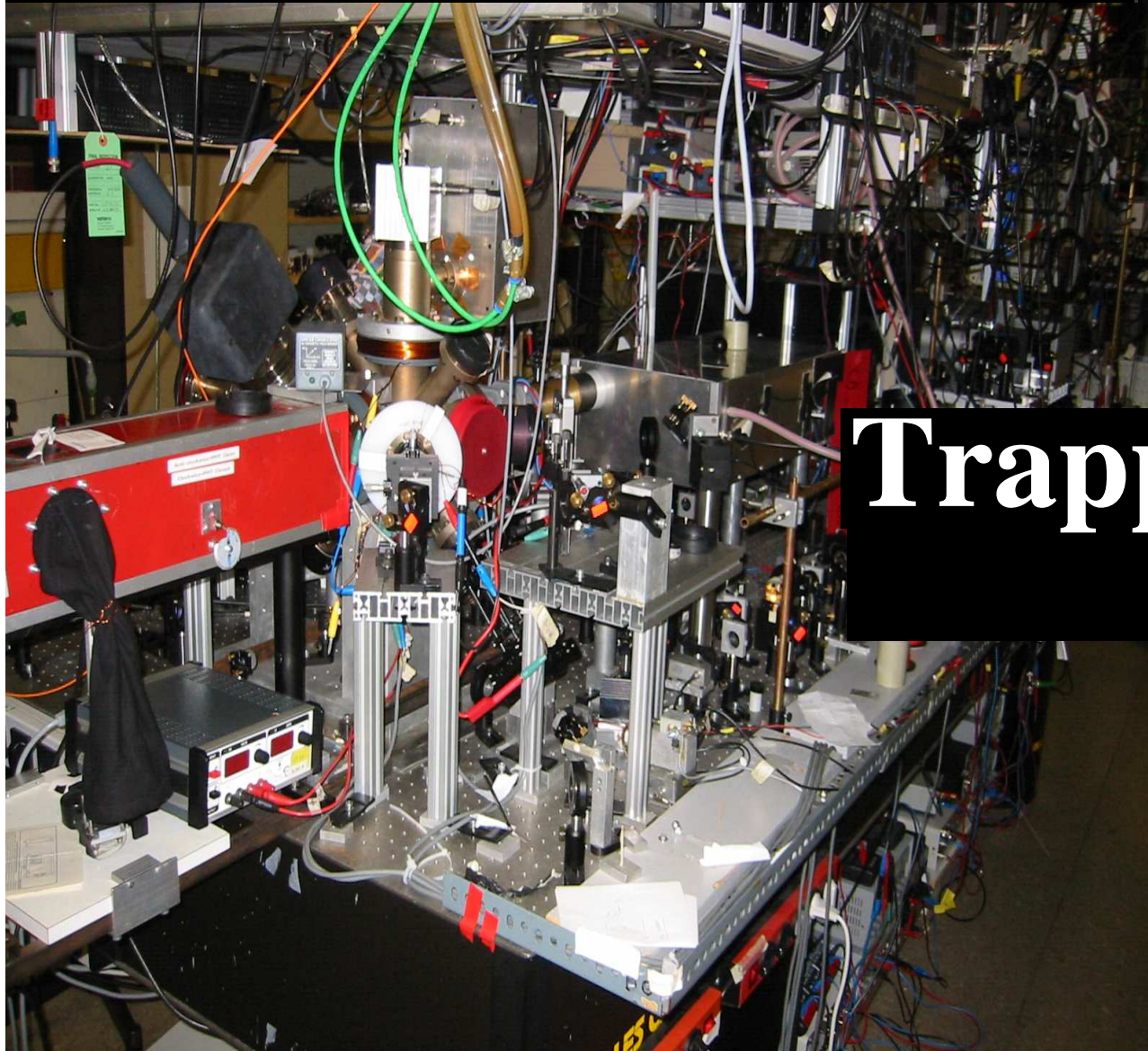

Trapped Ions

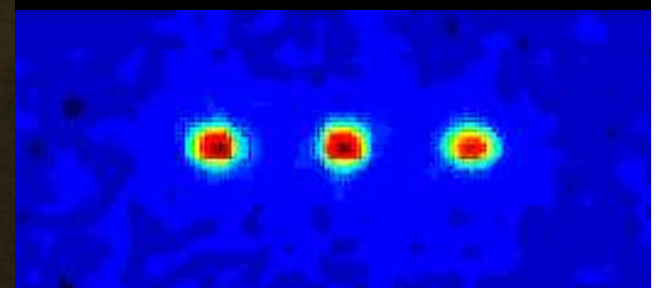
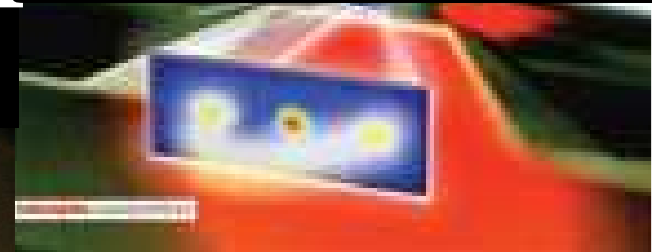

Quantum measurement

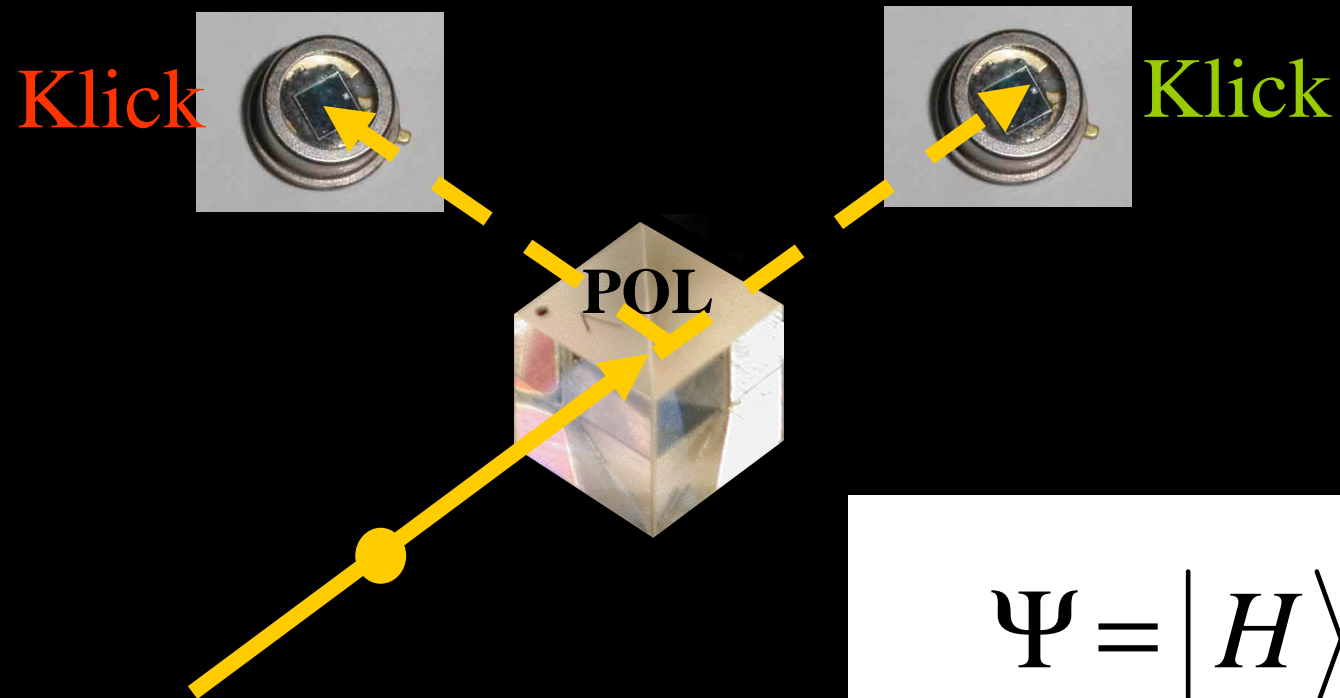

Quantum measurement

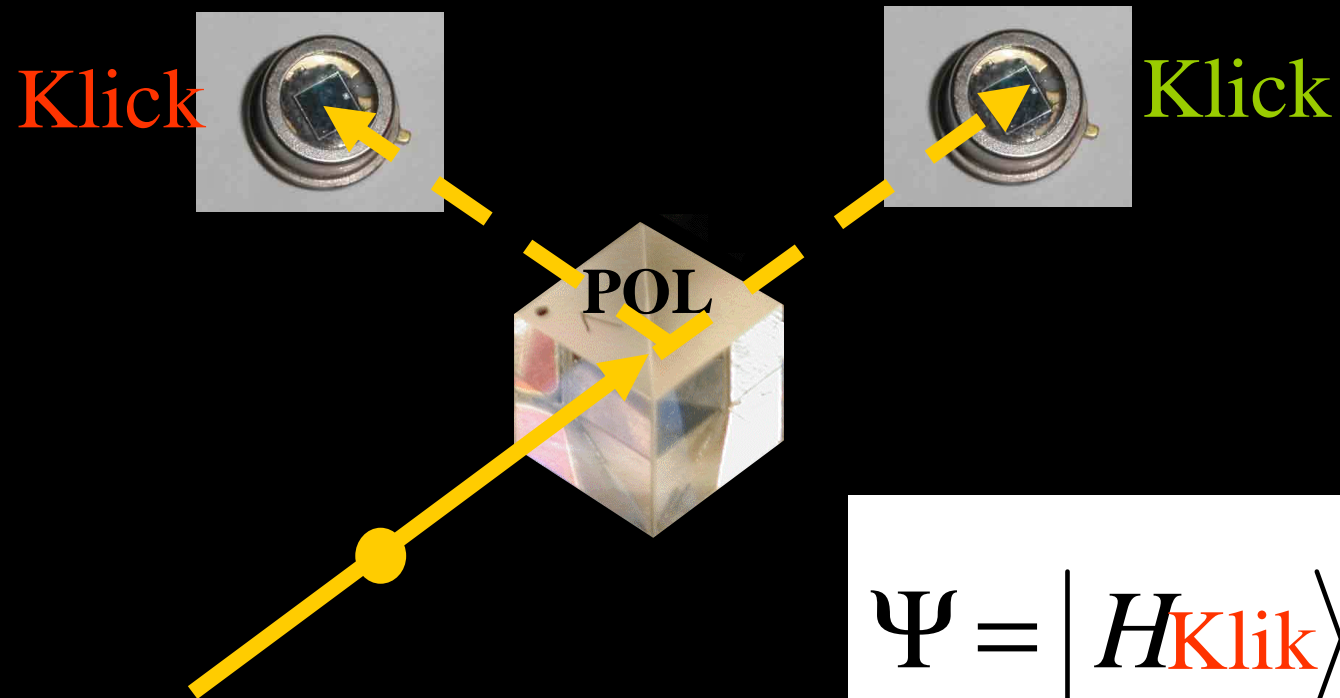

Quantum measurement

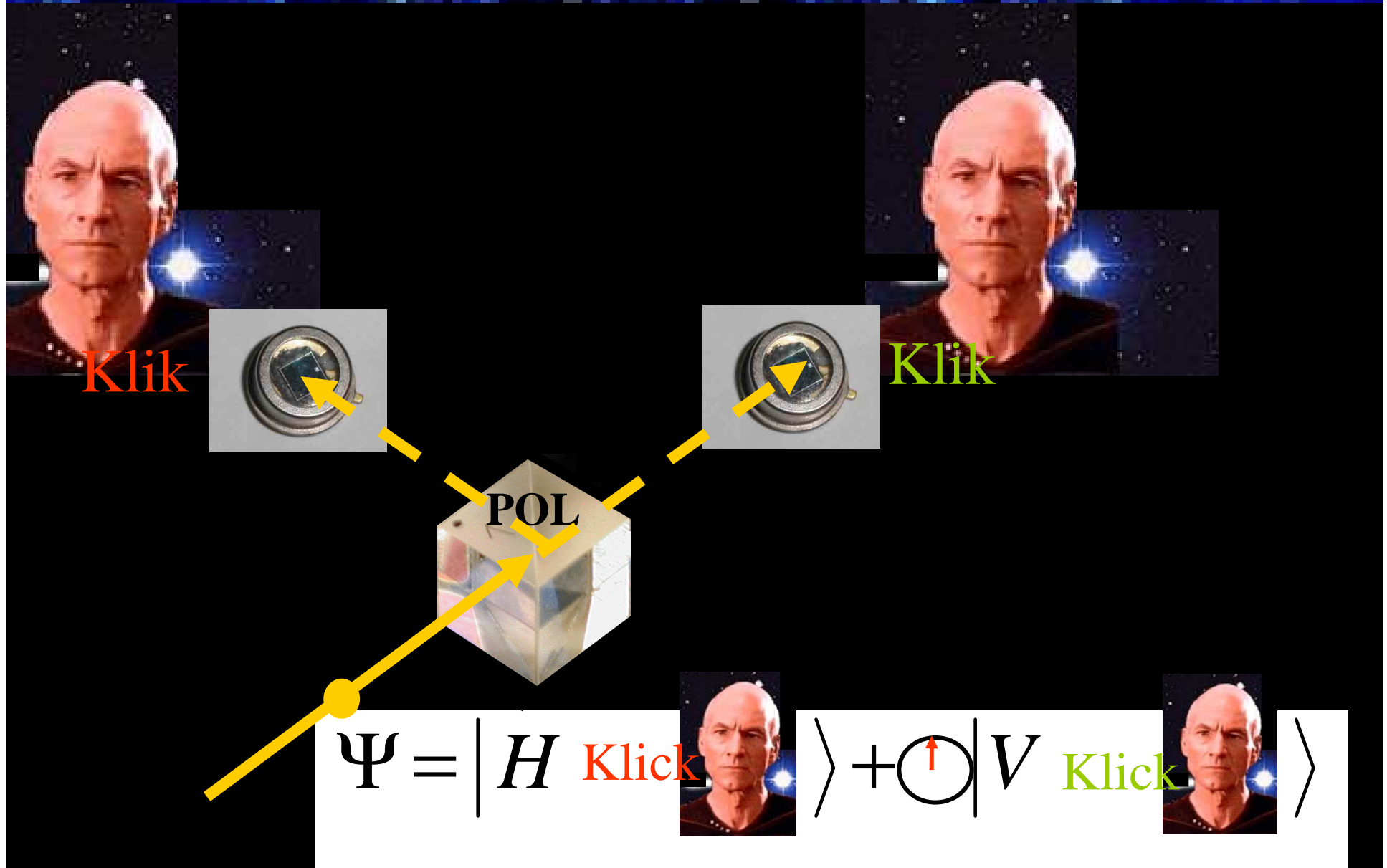

The quantum wavefunction $|\Psi\rangle$ is the representation of the real state of a system

Many Worlds Interpretation



A Cosmic Microwave Background (CMB) fluctuation map showing temperature variations across the sky. The map is a circular projection with a color scale from blue (cooler) to red (warmer). A dark blue rectangular box is overlaid on the upper portion of the map.

No quantum measurements are being performed on the universe. Therefore quantum correlations are preserved.

?

Ψ
Universe

Vaidman's watch

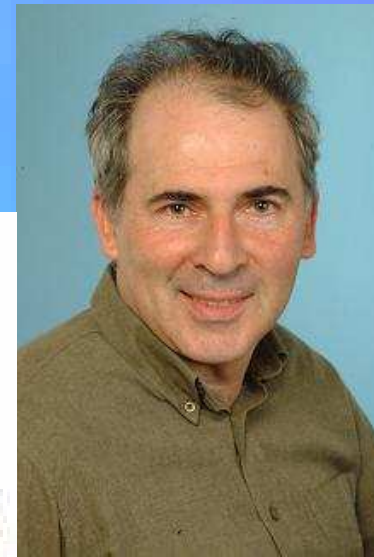
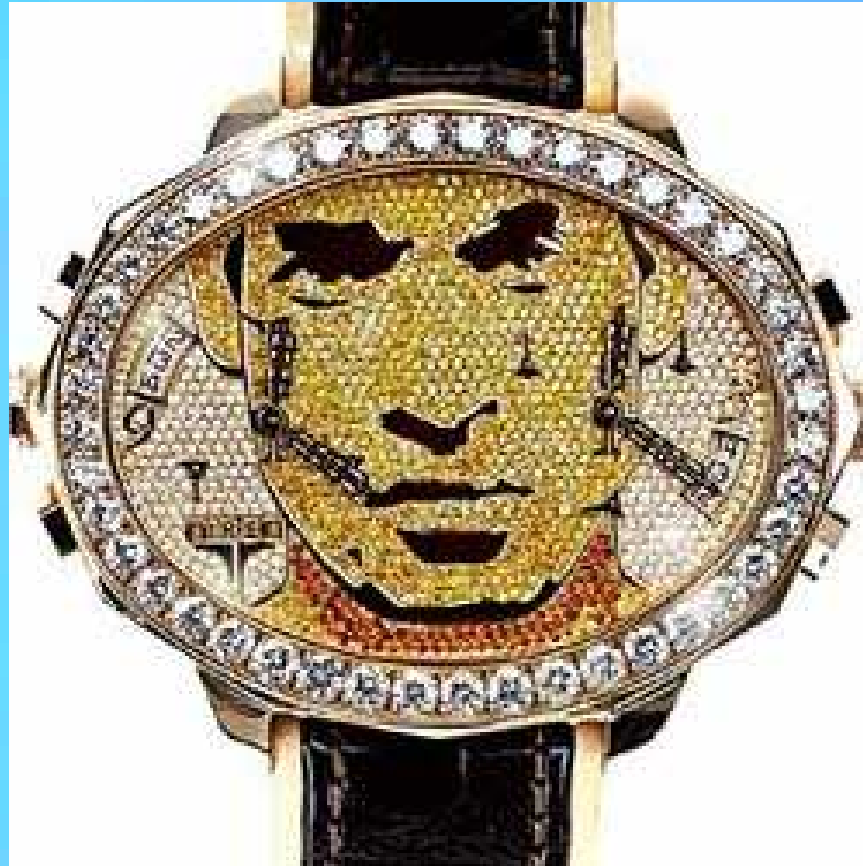

Photon source



Penrose:

The concept of a quantum superposition and the principles of general relativity are inconsistent with one another.

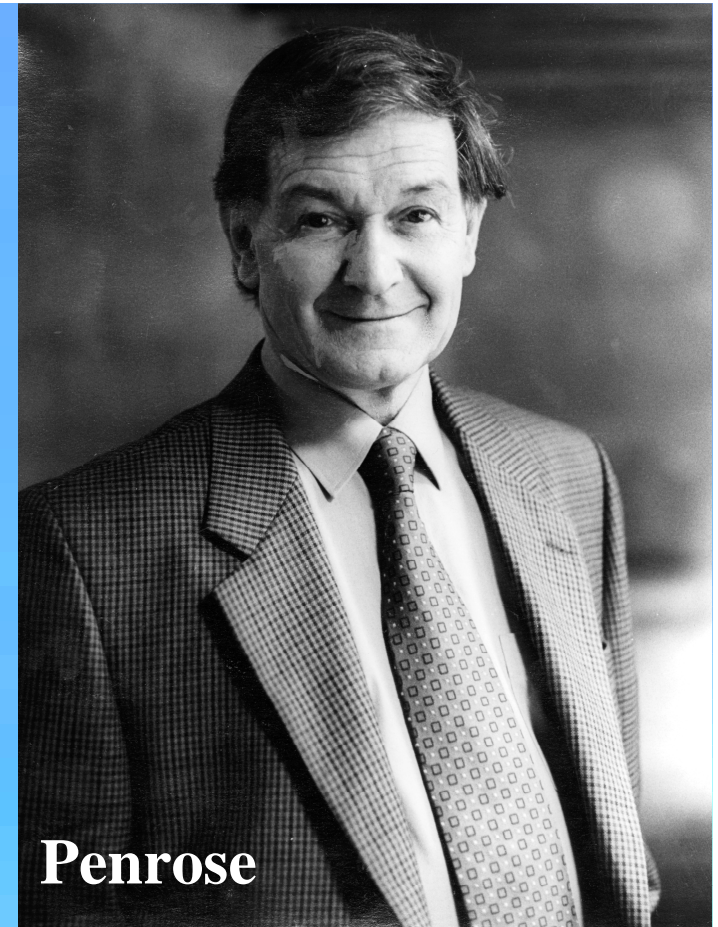

Penrose

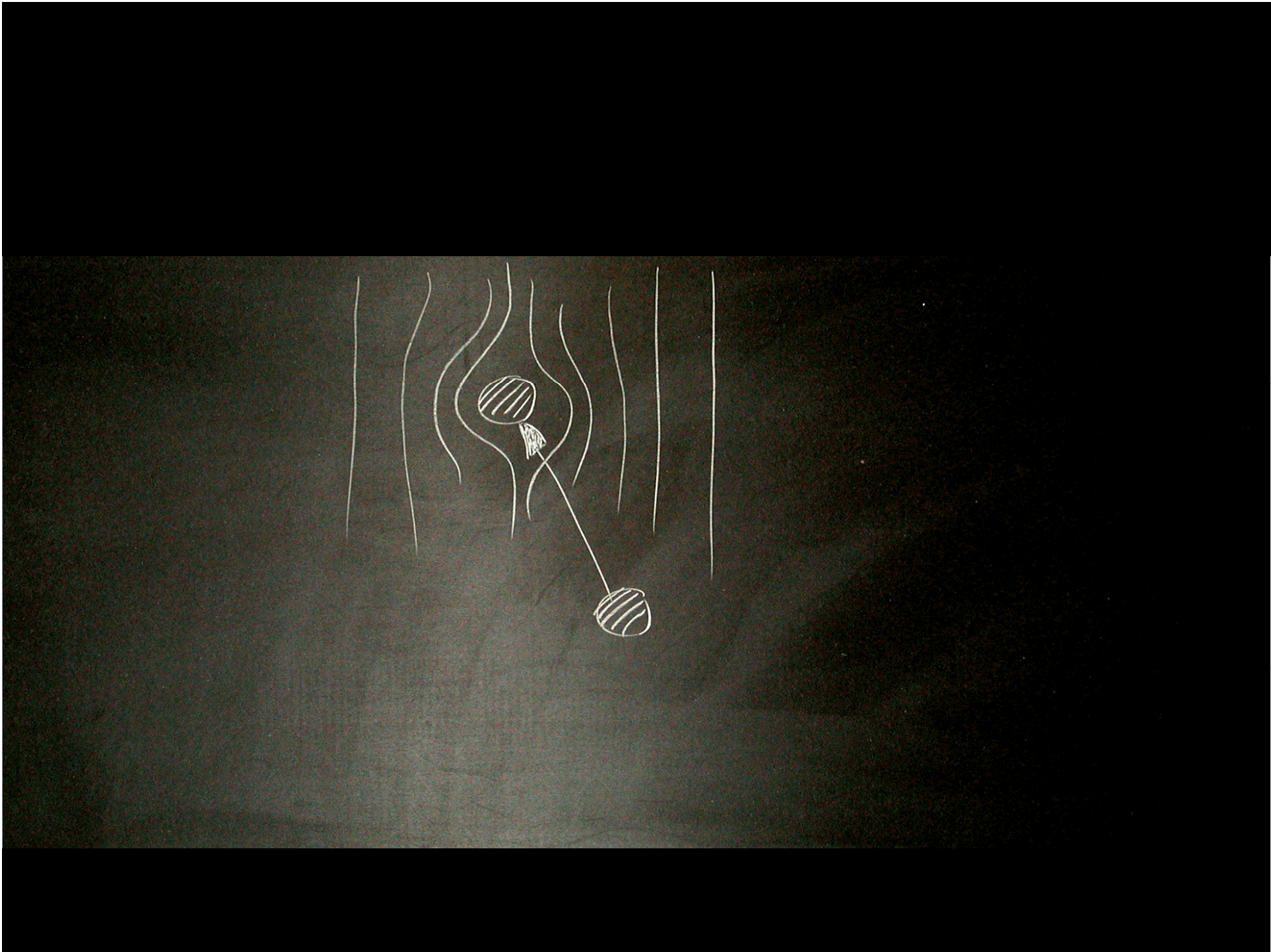

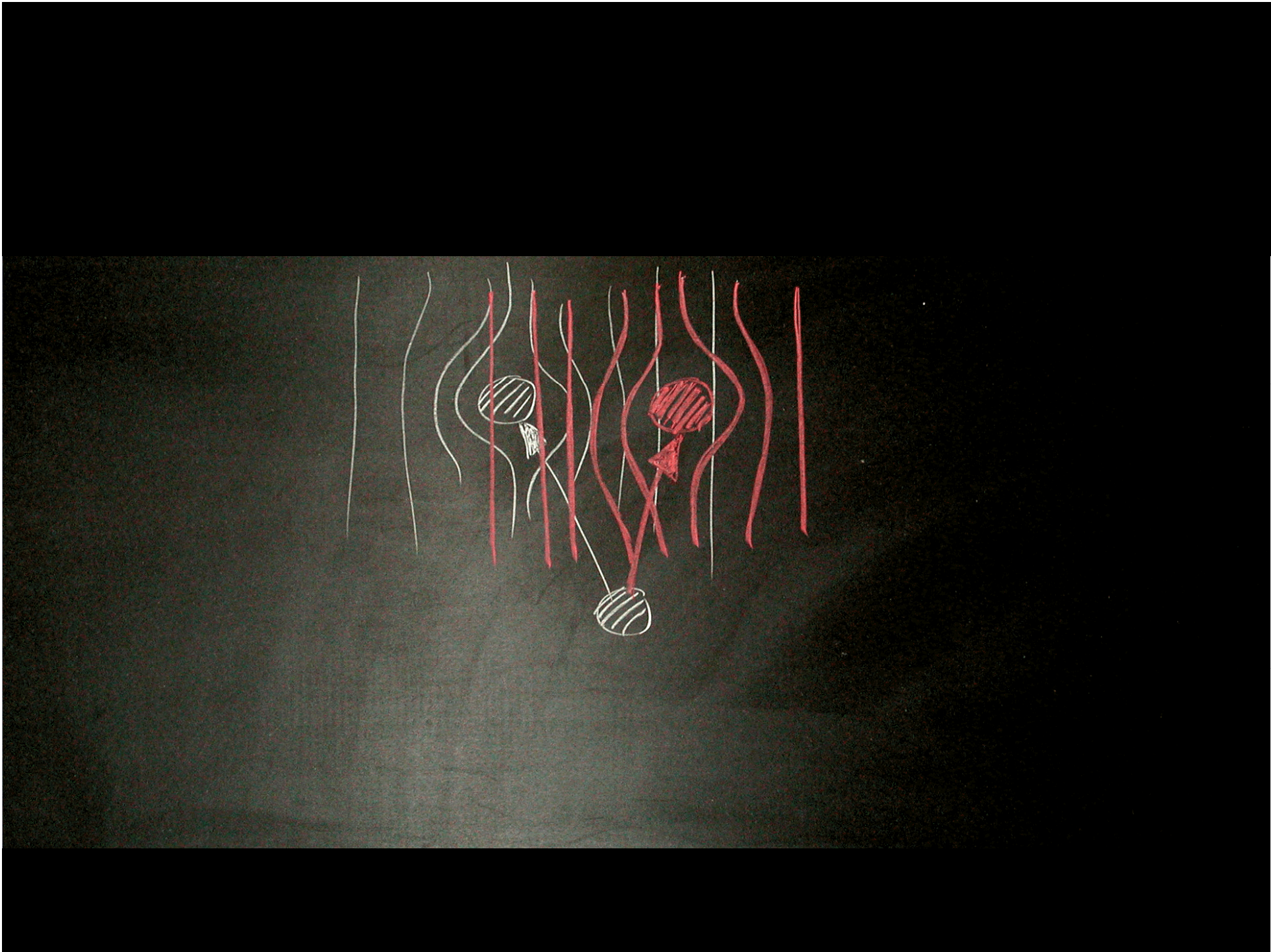

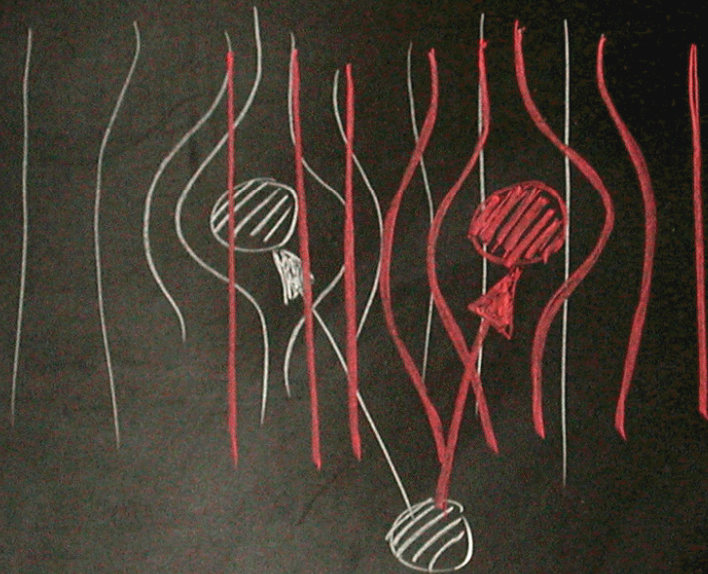

$$\Delta E_g \Delta t \geq \hbar$$



Towards Quantum Superpositions of a Mirror

W. Marshall, C. Simon,
R. Penrose, and D. Bouwmeester
Phys. Rev. Lett. 91, 130401 (2003).

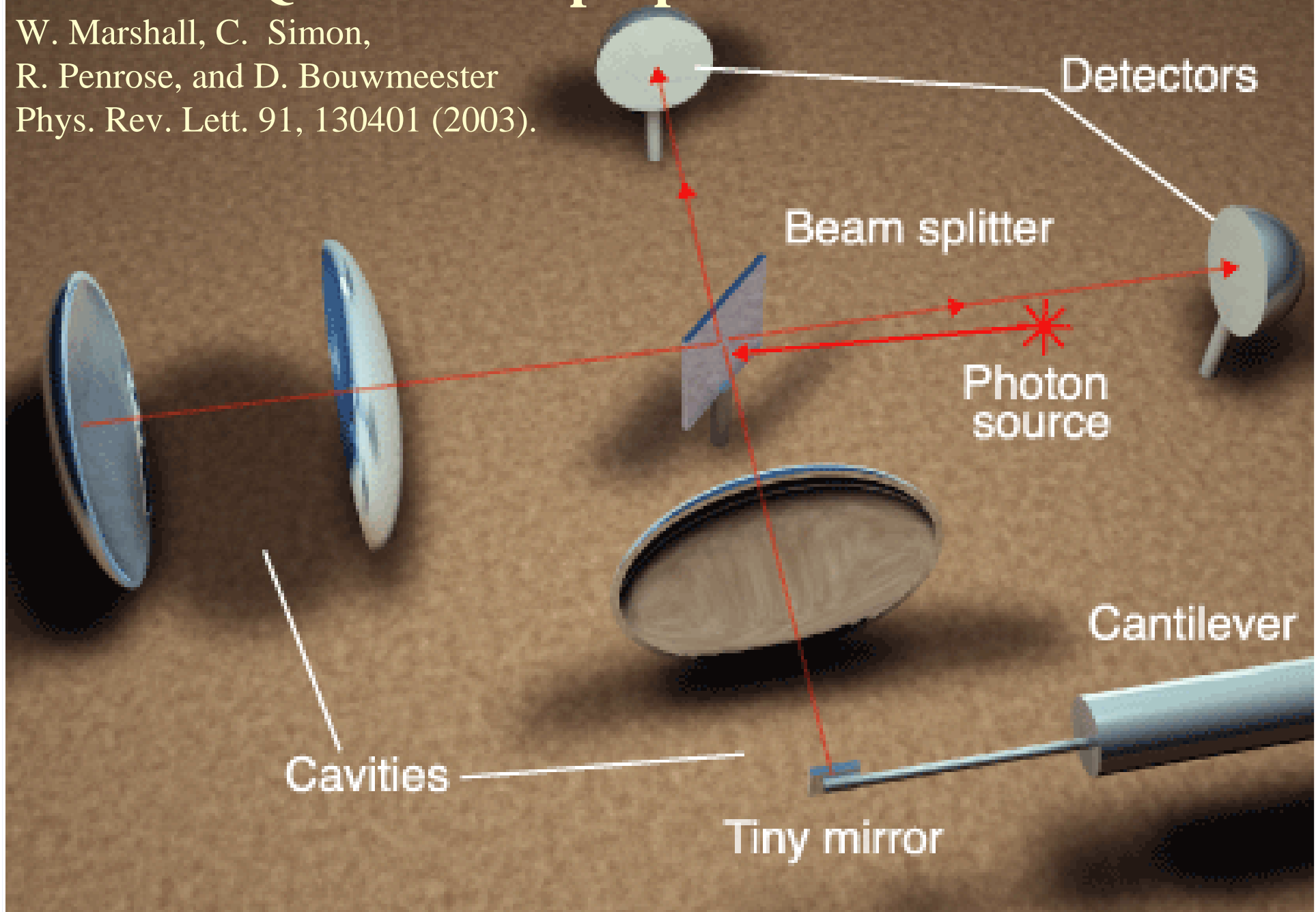

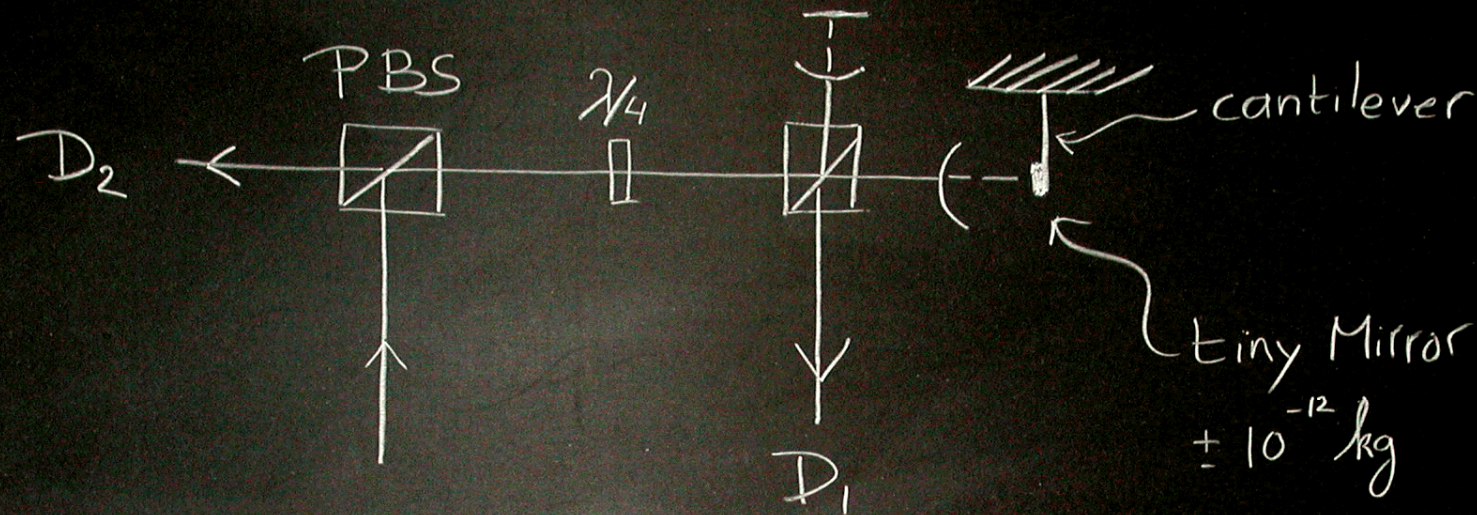

$$\mathcal{H} = \hbar\omega_c a^\dagger a + \hbar\omega_m b^\dagger b - \hbar g a^\dagger a (b + b^\dagger)$$

$$g = \frac{\omega_c}{L} \sqrt{\frac{\hbar}{2M\omega_m}}$$

Law, PRA, **49**, 433 (1993)

Bose et al. PRA **59**, 3204 (1999)

Marshall et al. PRL **91**, 130401 (2003)

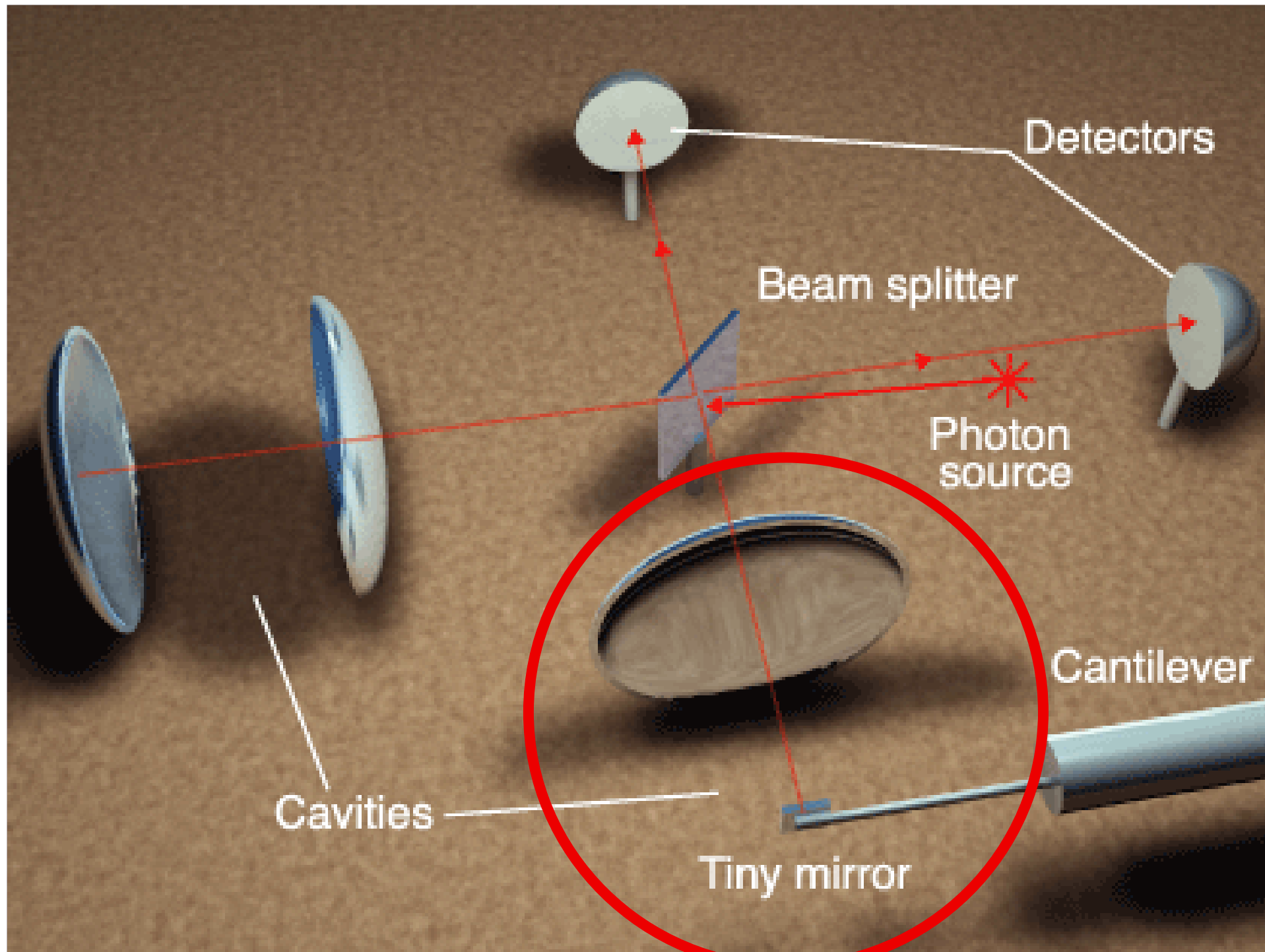



UCSB

Laser

780nm

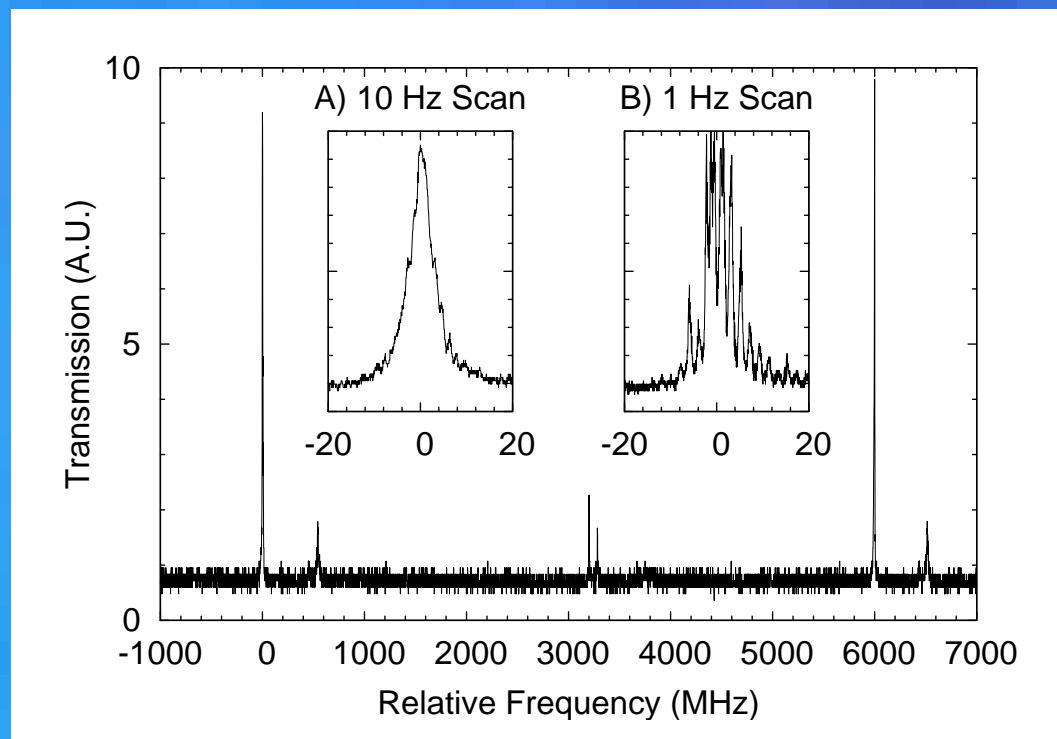
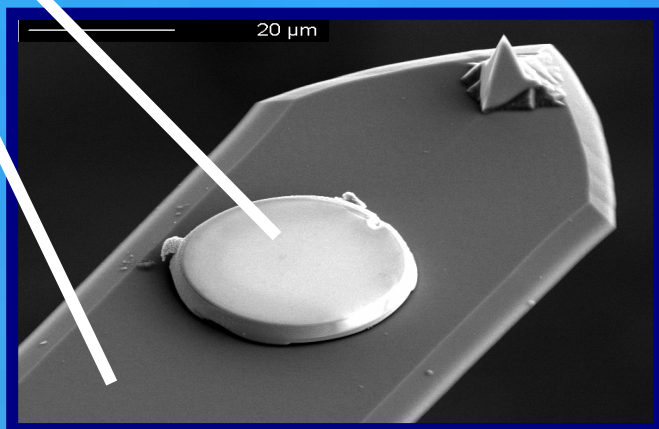
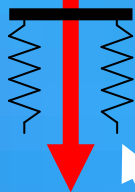

ΔX

Cooling by light radiation

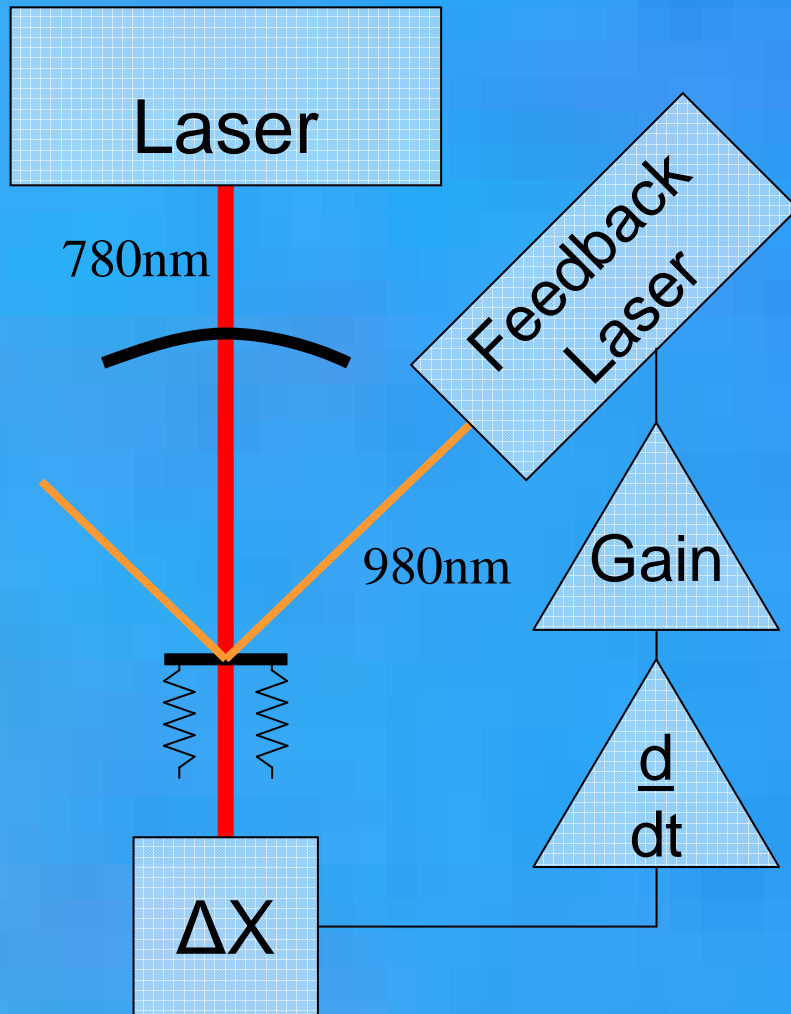

Cooling by light radiation

Spectral Noise Density ($\text{\AA}^2 / \text{Hz}$)

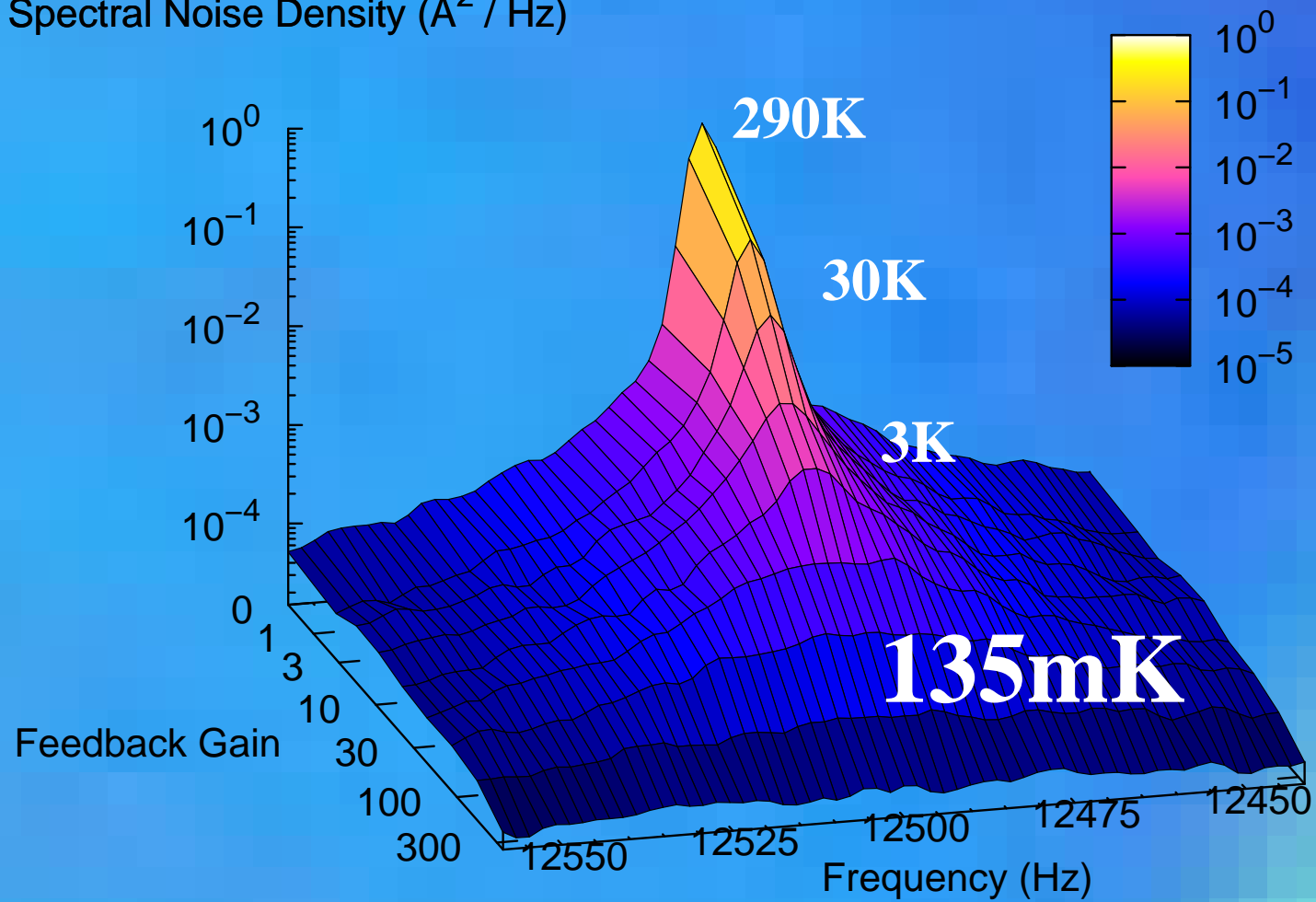

Leiden, the Netherlands



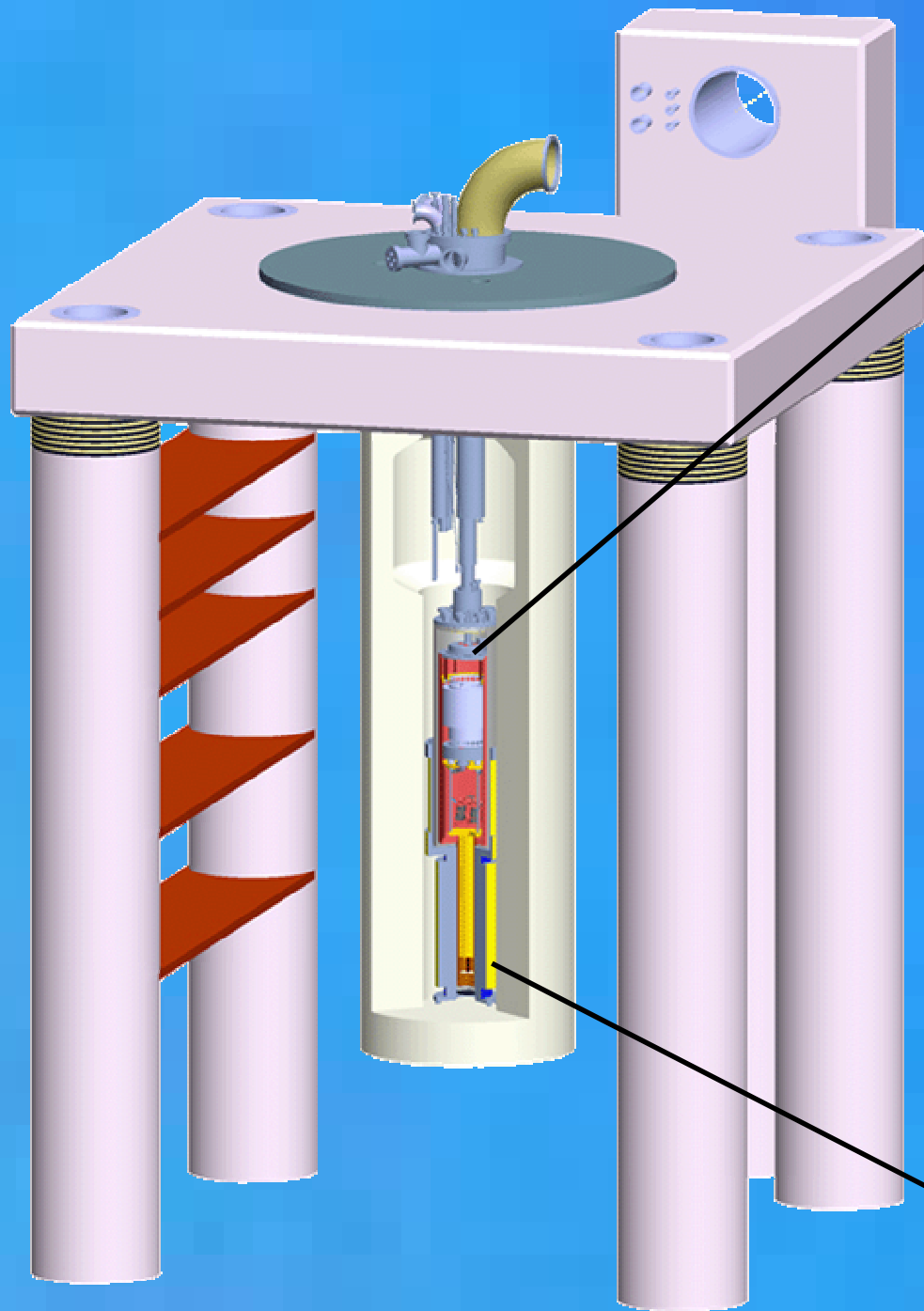

Dilution refrigeration
10mK

Optical cooling
100nK

Nuclear cooling
100 μ K

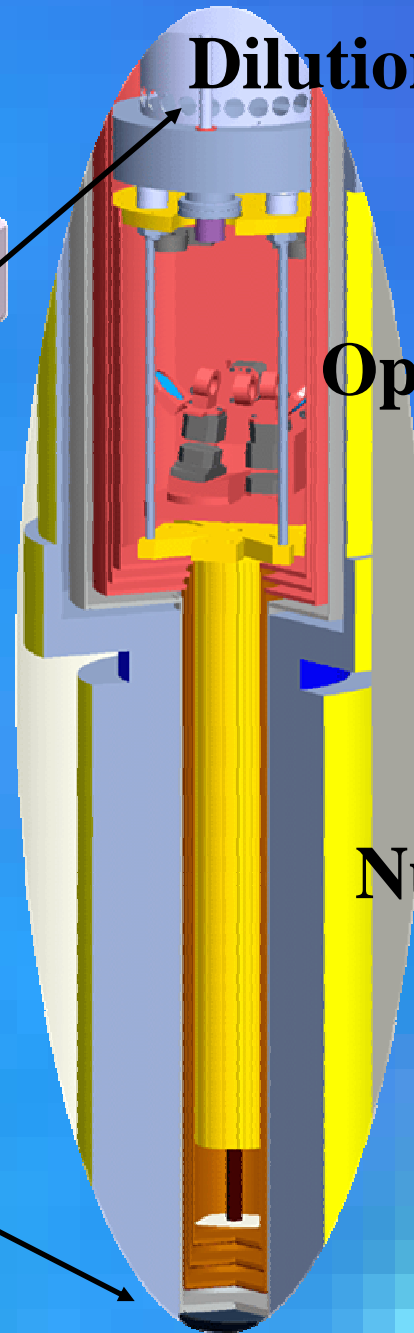

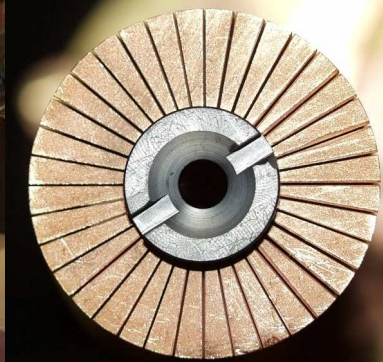

3rd generation optical setup

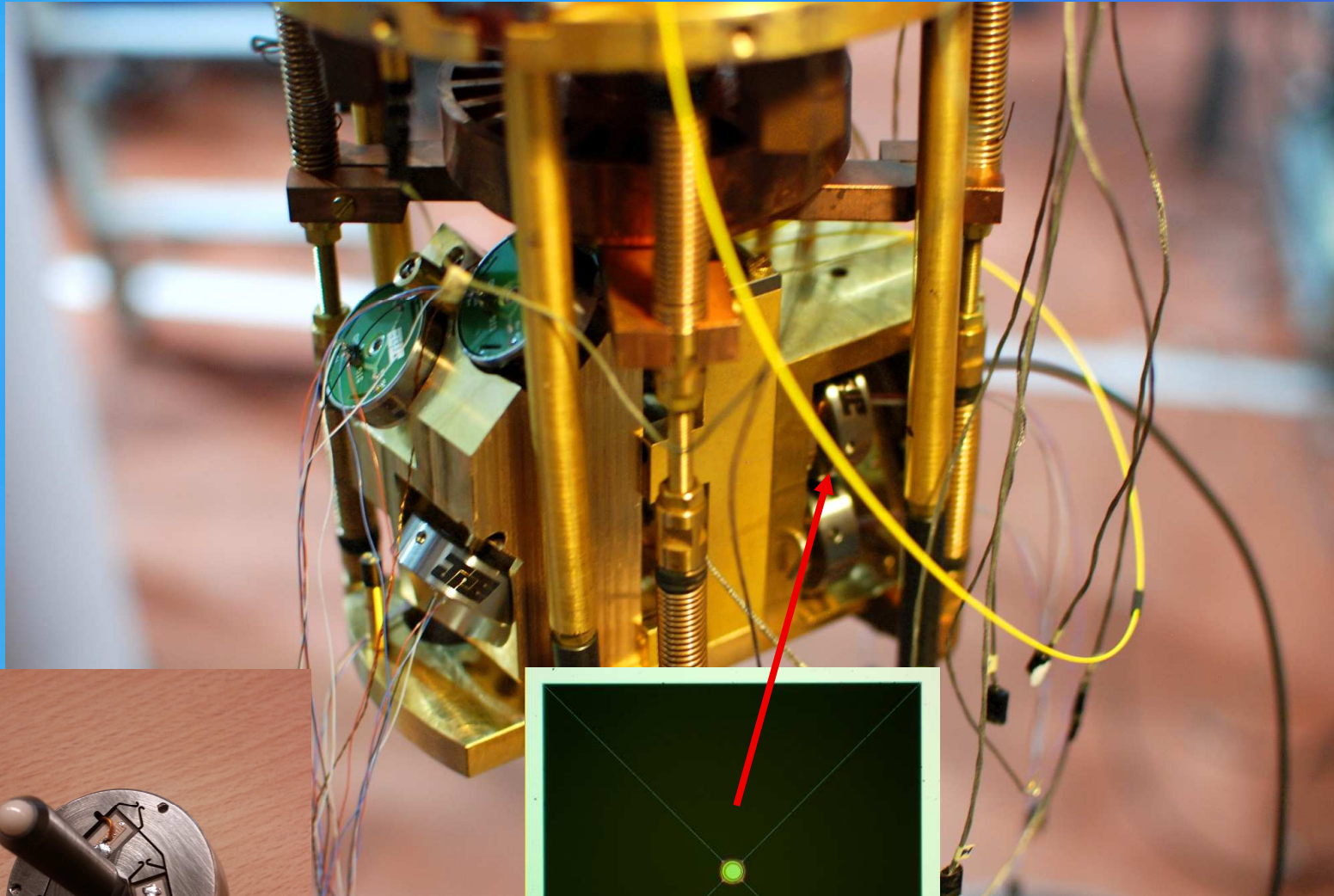

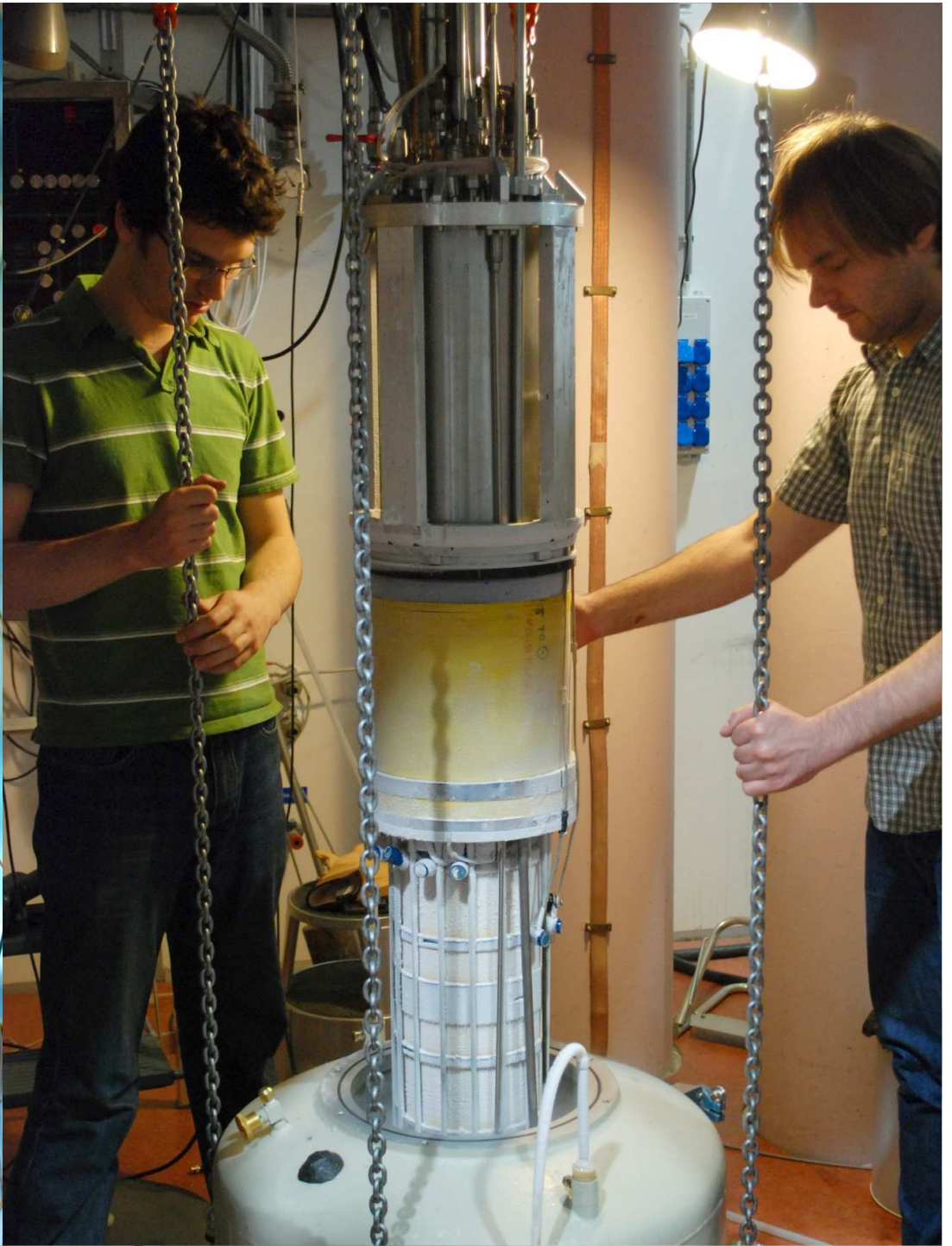
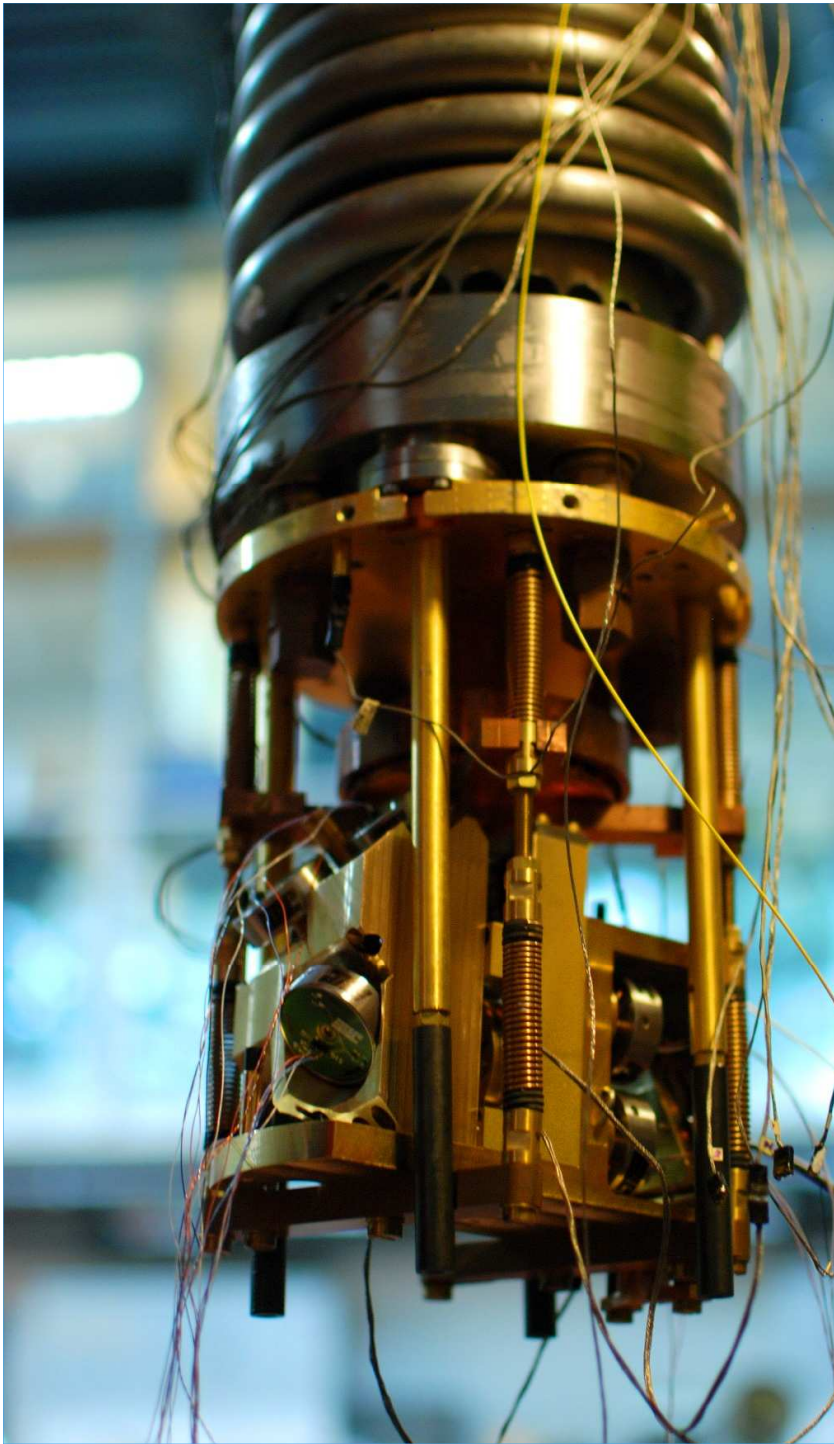

First optical cooling results in dilution refrigeration system

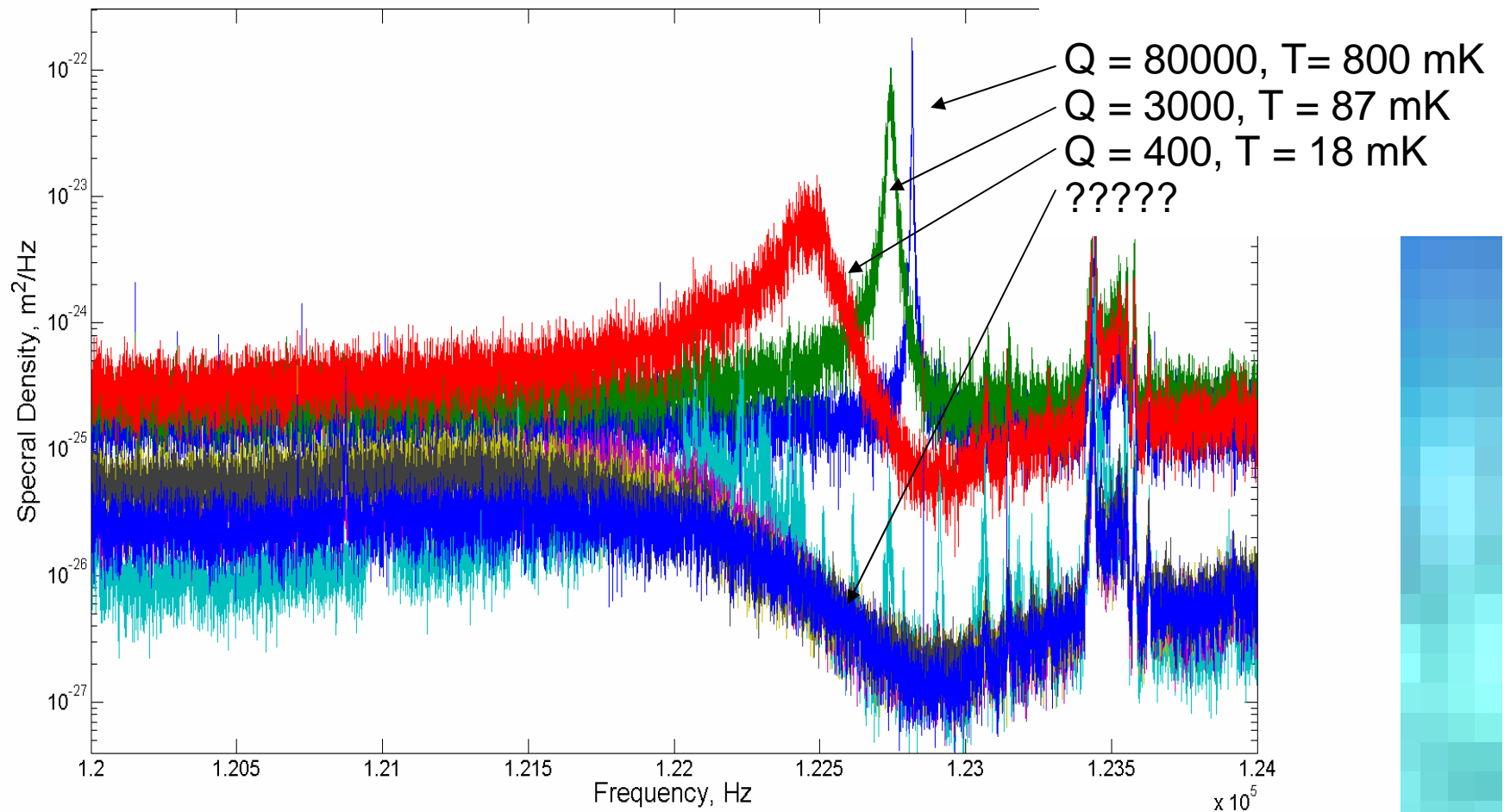

Based on peak suppression lowest curve $T < 800 \mu\text{K}$, $n < 150$

2004

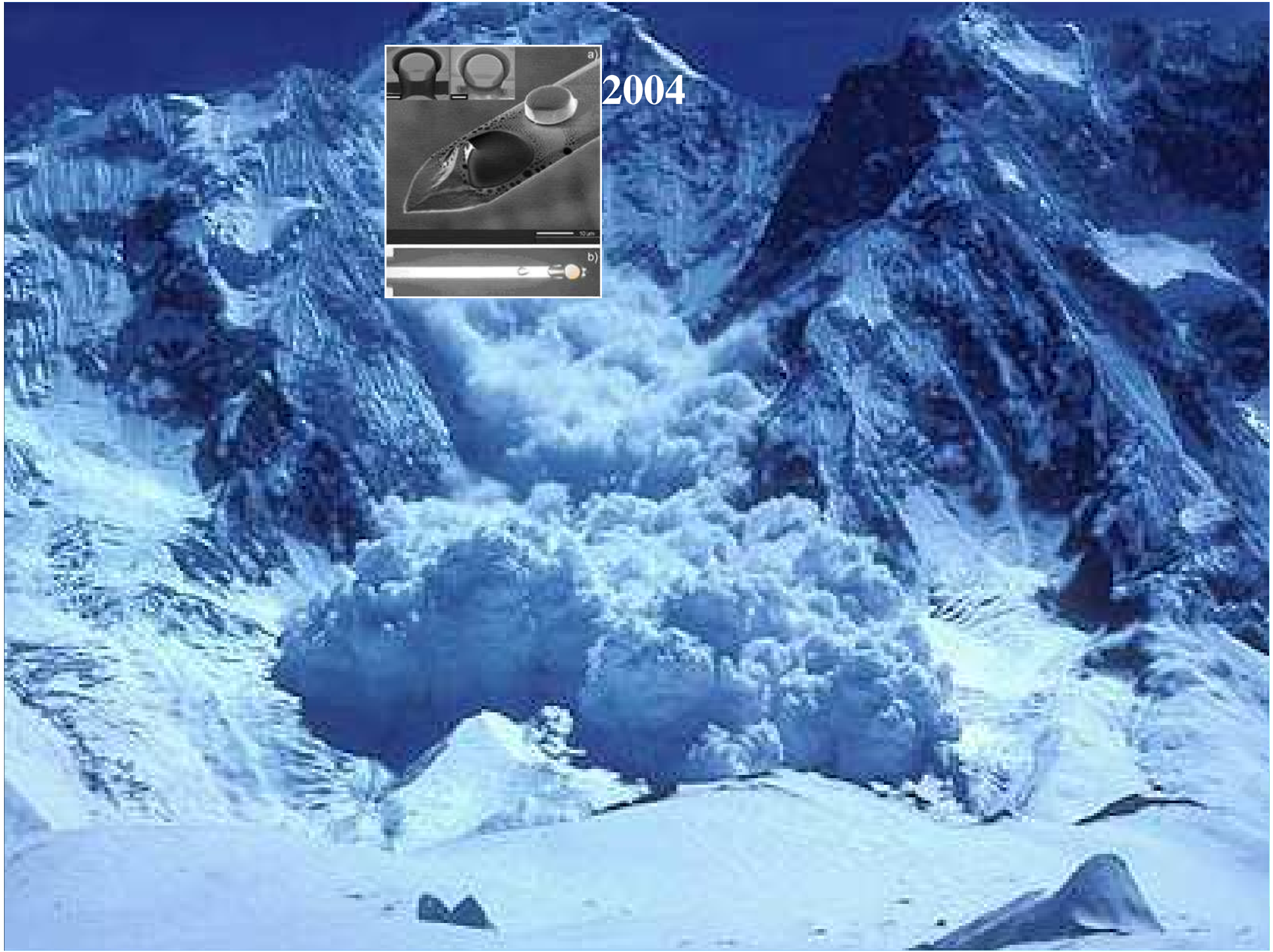
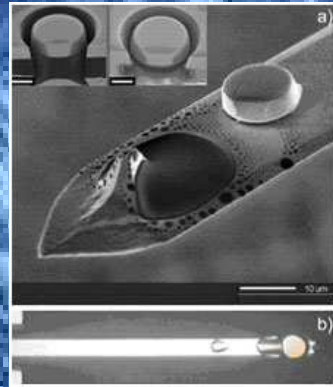

2004

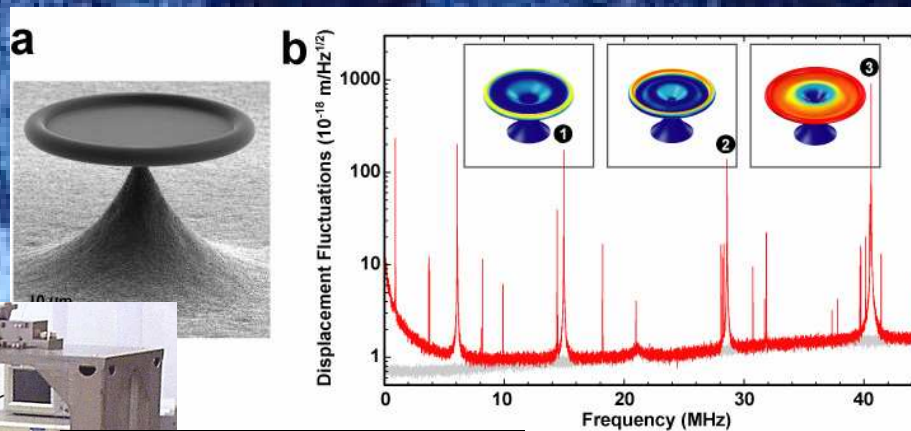
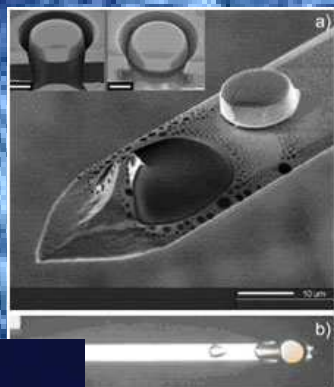

2007

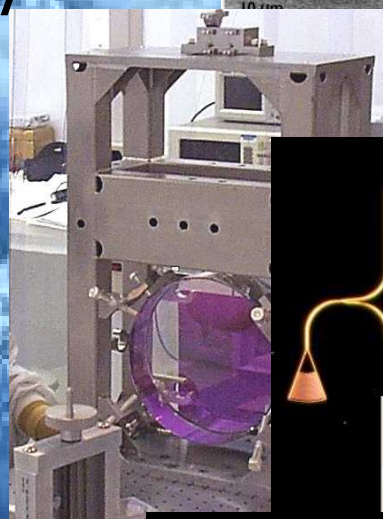
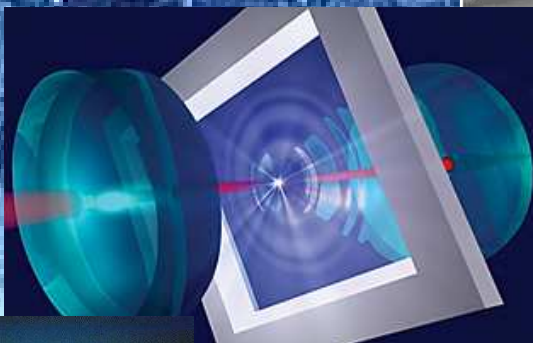

2010

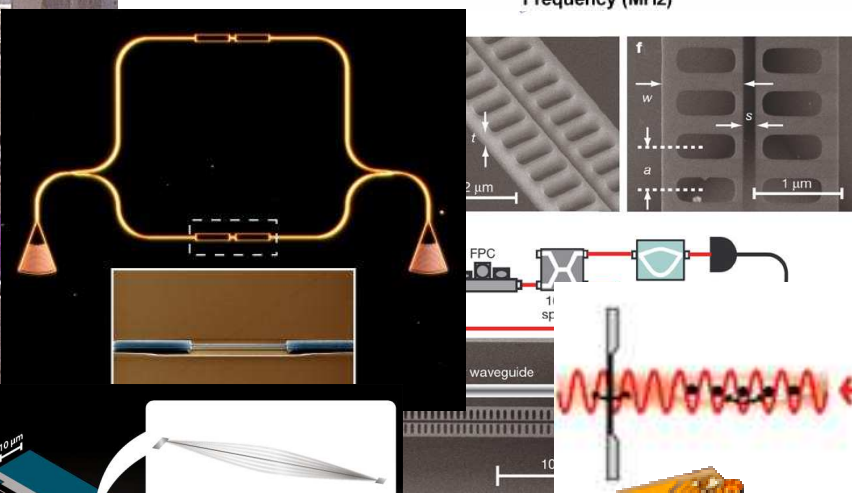

2011

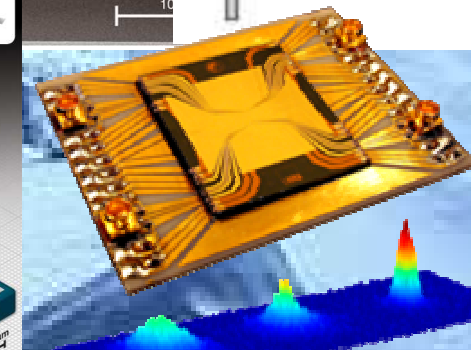
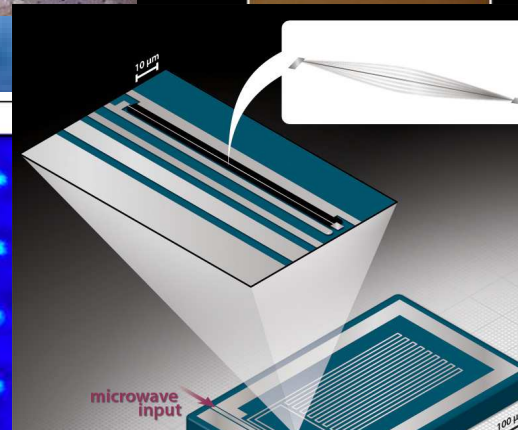
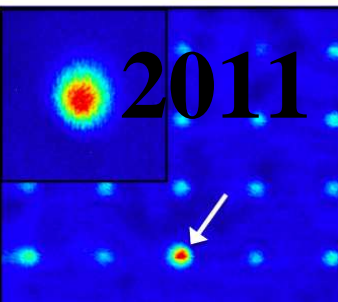
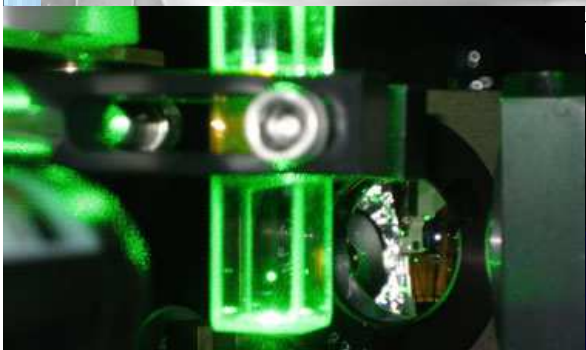



2004

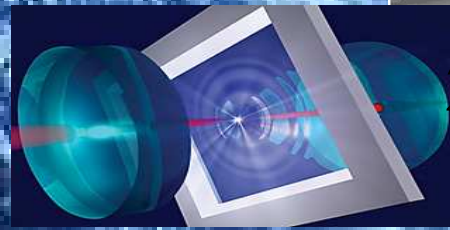
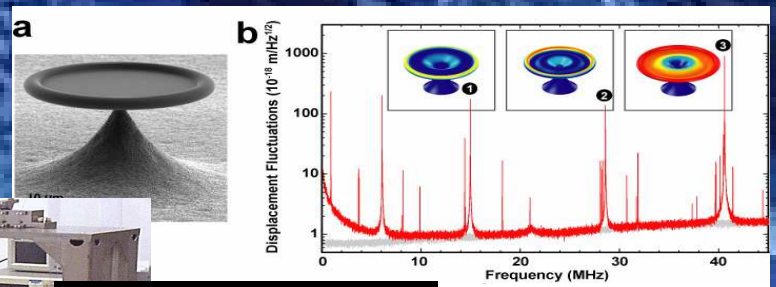

2007

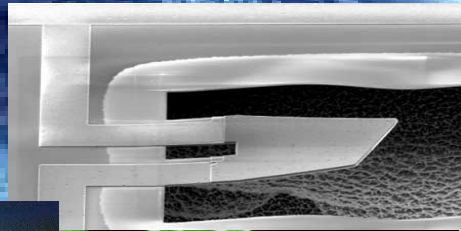

2010

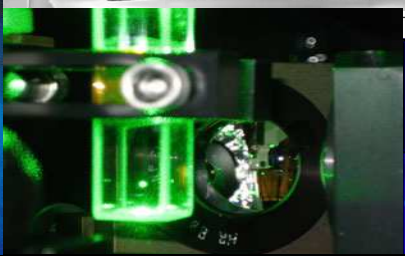
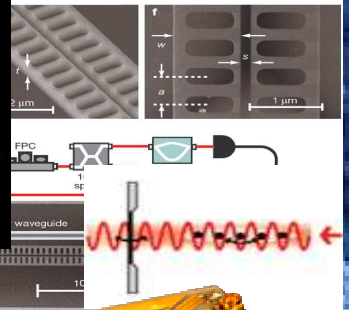
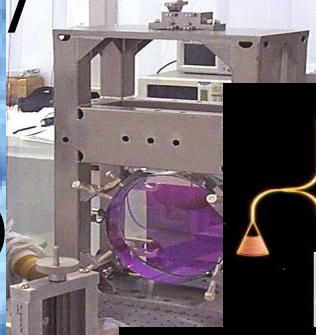

2011

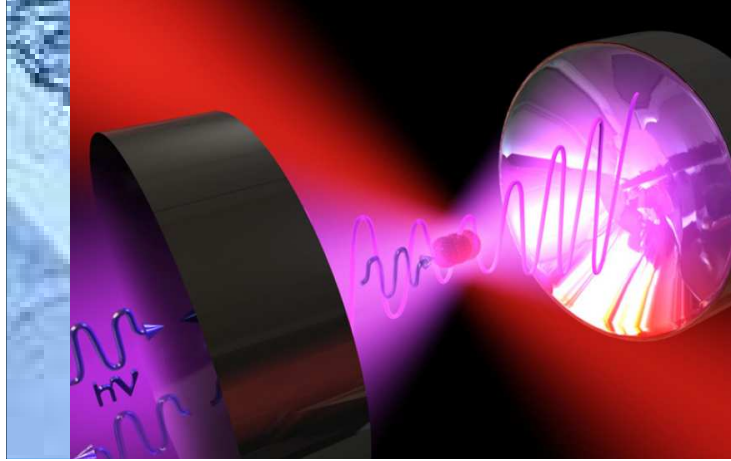
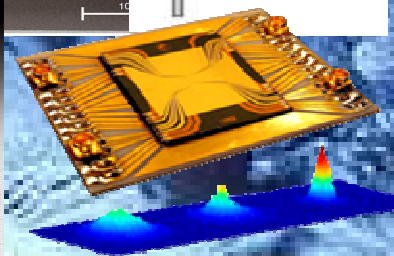
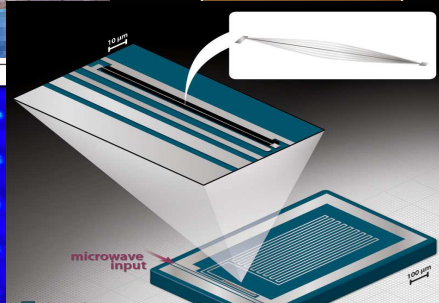
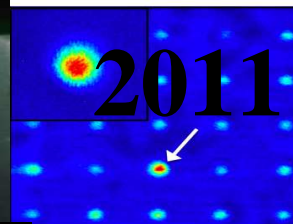

2020



OR





2004

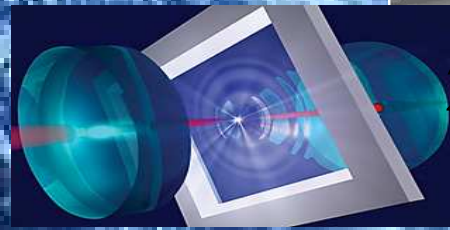
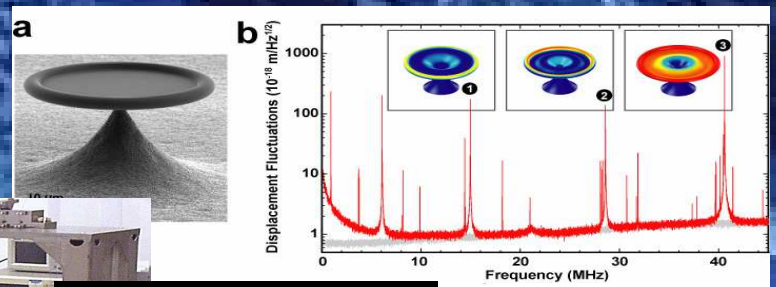

2007

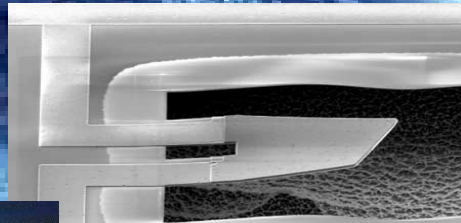

2010

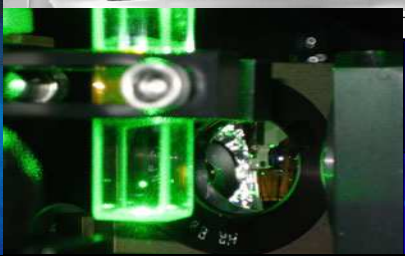
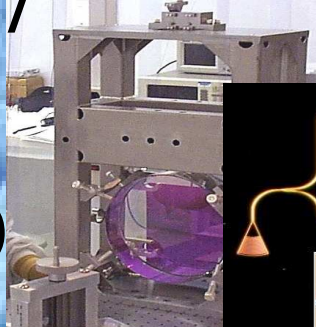

2011

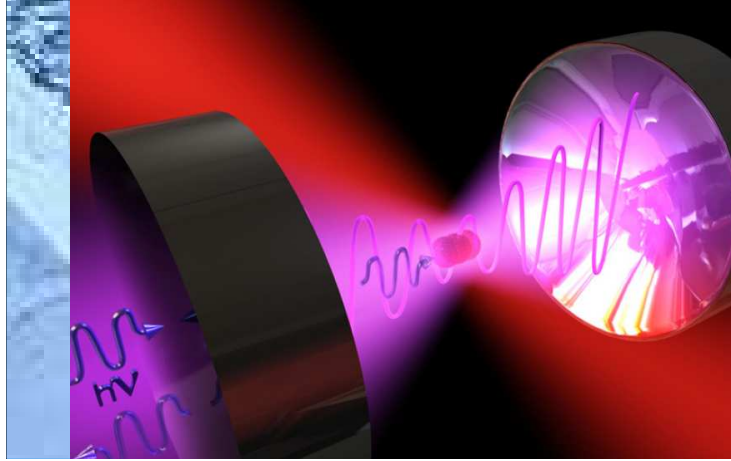
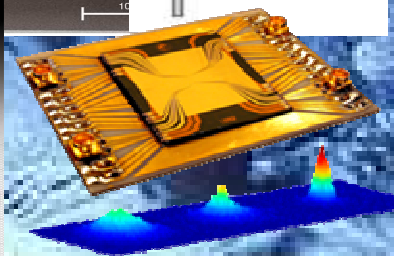
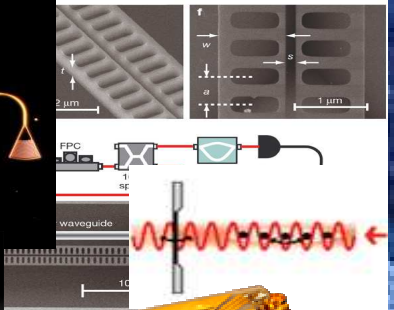
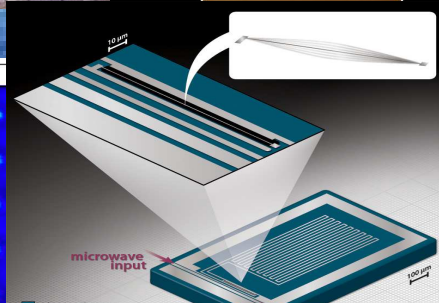
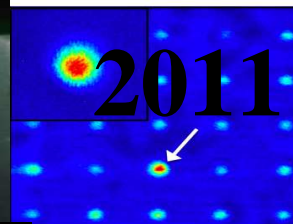

2015

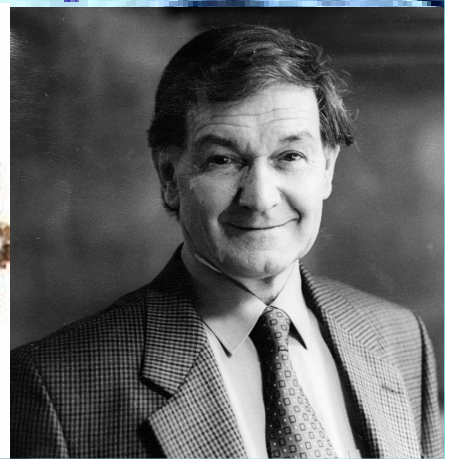
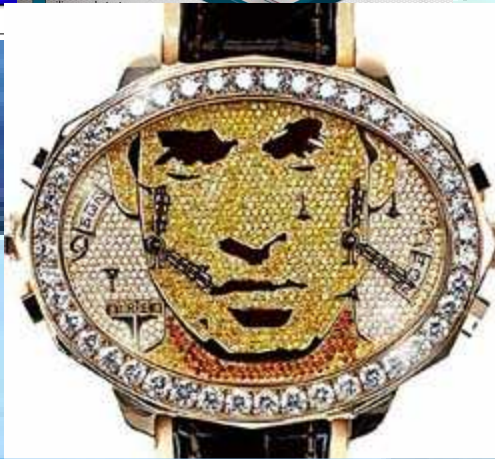

Summary:

Quantum theory describes the structure of atoms, molecules, materials, biology, life.

Quantum entanglement explains the emergence of a classical reality from an underlying quantum world. This seems to allow the existence of “many worlds”.

Prediction: As a result of gravity macroscopic superpositions will rapidly decay. This would result in a single classical reality (but requires new physical laws).

New experiments are needed (at 0,000001 Kelvin, Leiden,...).

Quantum Applications: quantum cryptography, quantum teleportation, quantum computation